

# Standard Flat Roof

## Assembly Guide

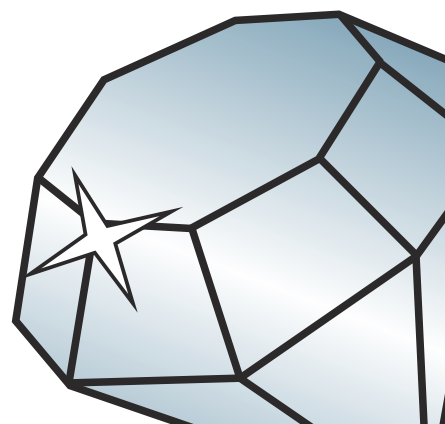

DURATION  
WINDOWS



# Step One

## Cill Assembly

- If your roof has been made with a cill please follow the instructions below for assembly.
- If you are not using a cill section please skip forward to ring beam assembly on the next page.

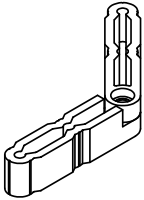

**ACET440**

90°-180° Variable angle bracket

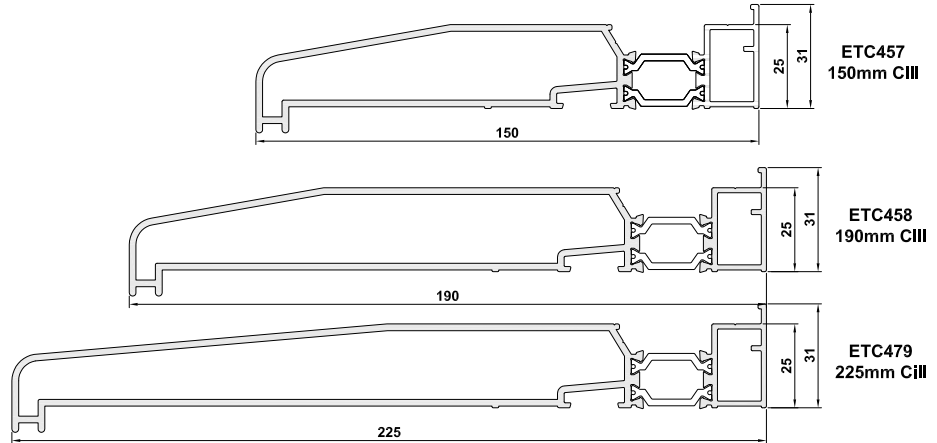

Ends of cills shall be dammed and sealed to prevent water egress

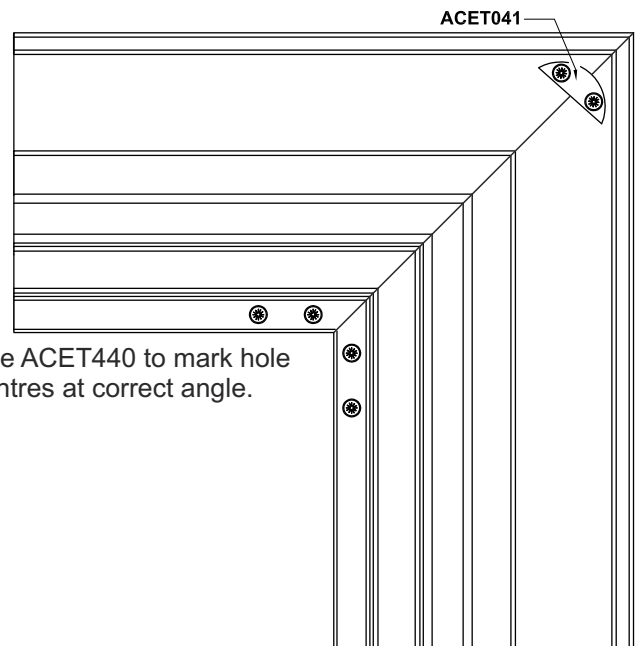
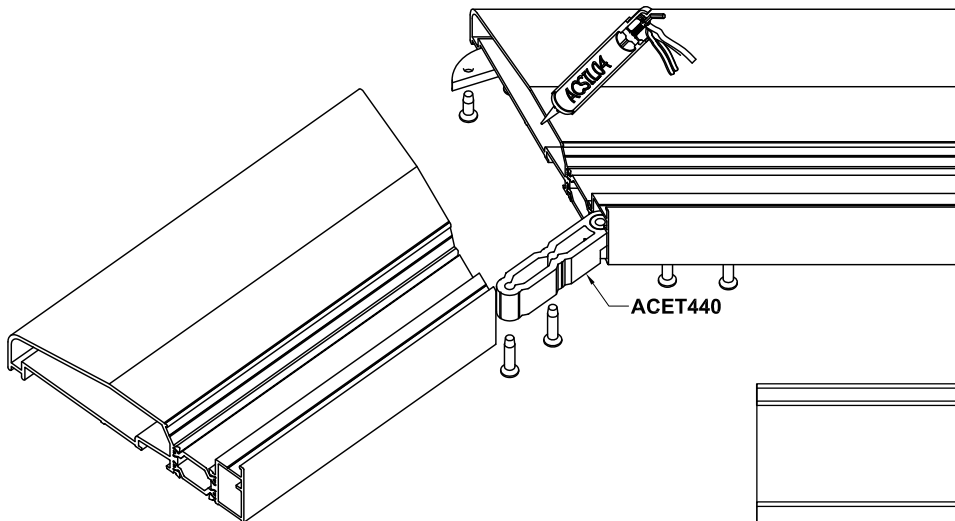

Use ACET440 to mark hole centres at correct angle.

Once assembled bed down cill with an appropriate sealant on top of your kerb and screw fix down. Please make sure all screws are silicone joined for water tightness.

# Step Two

## Ring Beam Construction

- Parts



Standard Ring Beam



Ring Beam Clamp Bracket

- Assemble ring beam in an open area such as a lawn.

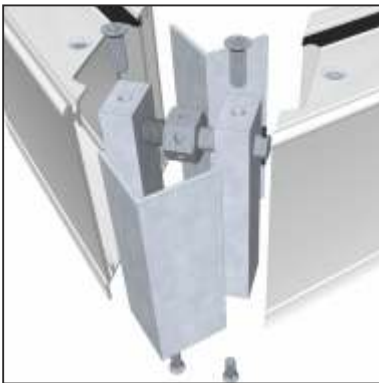

Insert corner cleats and clamp bracket into one section of the ring beam. Screw into place using screws provided.



Take the next section of ring beam and screw into place. Silicone screws in place to make water tight.



Silicone edges of ring beam then tighten the clamp bracket until both the sections of ring beam are flush with each other. Repeat until all sections of ring beam are connected.

## Ring Beam Fixing

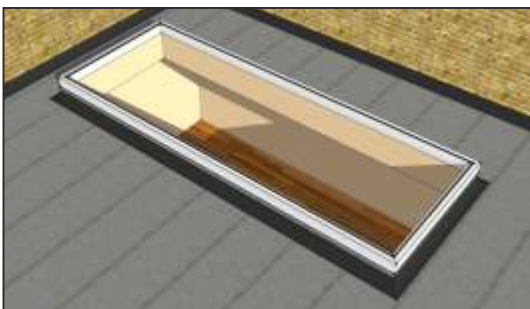

- Bed down the ring beam onto your kerb using an appropriate sealant.
- Screw fix ring beam into position.
- The ring beam is 112mm in height so a 150mm screw or larger will be needed.
- Fixings can be hidden by positioning them below the rafters. Note fixing holes will need to be drilled on site and counter sunk.
- Make sure all fixing points are silicone joined for water tightness.

### When using a cill:

- Please note if a projection cill is being used below the ring beam this needs to be silicone joined at the back and to the ring beam.
- Again please silicone join all fixing points for water tightness.

# Step Three

## Fixing Glazing Rafter To Ring Beam

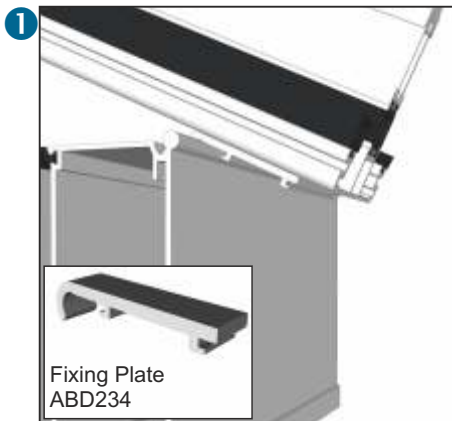

- Insert fixing plate (ABD234) onto ring beam support.

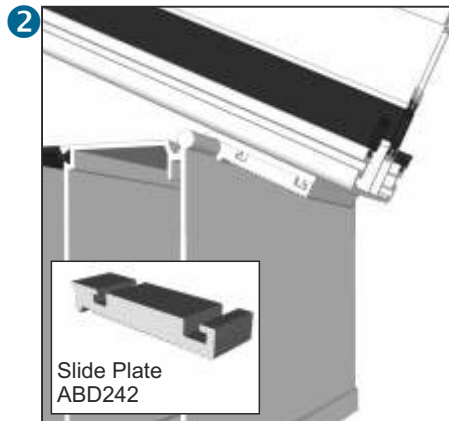

- Insert slide plate (ABD242) into position showed on fixing plate.



- Insert screws through the glazing bar, fixing plate and slide plate.

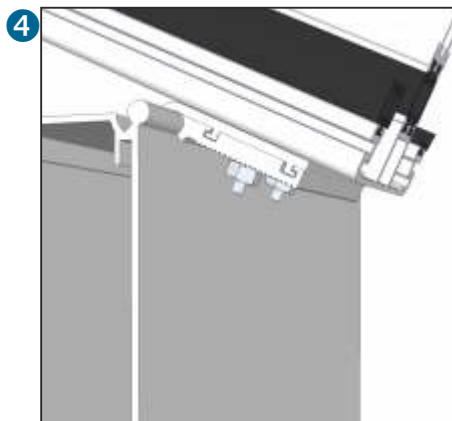

- Start to screw bolts into place until tight.
- Once fully tightened bar will be sufficiently held in place.

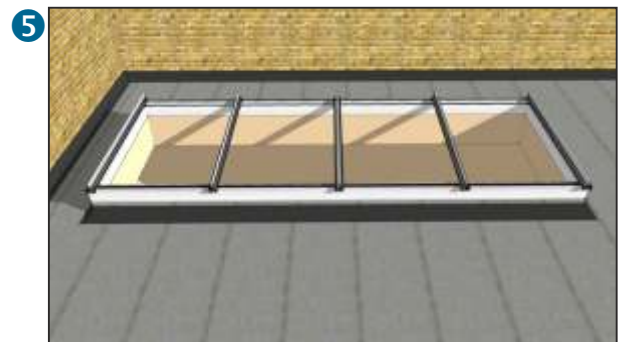

- Once bar is fitted to one side, lay bar flat and repeat the process on the other side of the ring beam.
- Do this until all bars are positioned and fitted in place.

## Fixing Ring Beam Infill Into Place

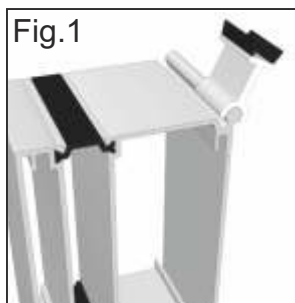
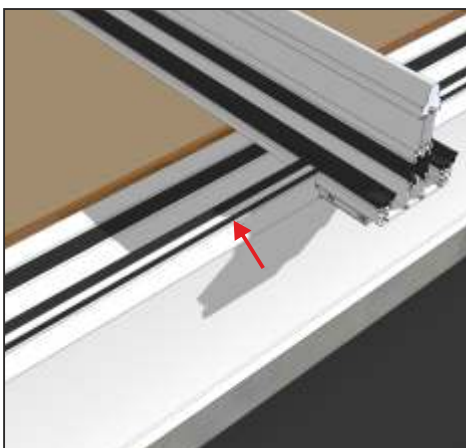
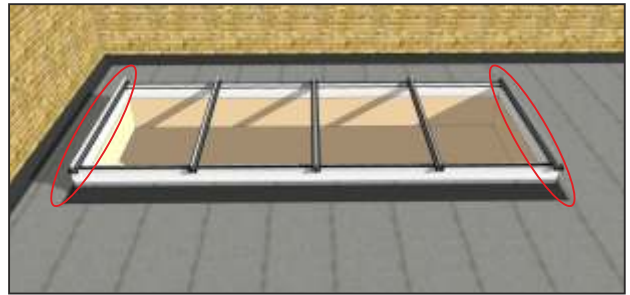
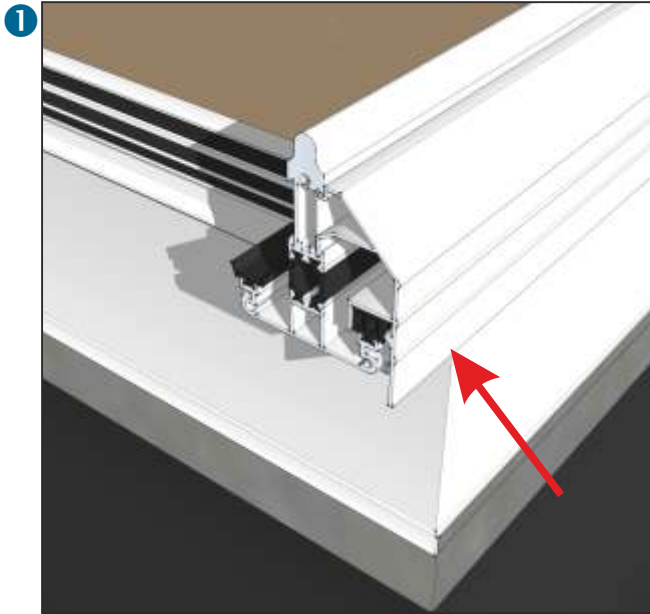

Fig.2

- Next snap the ring beam infill (ABD248) into position.
- The infill snaps onto the ring beam support (Fig.1) and goes between each glazing bar. (Fig.2)
- This helps space the glazing bars.
- Repeat until all infills are snapped into position.

# Step Four

## End Bar, End Caps & Infills



- Snap gable end bar (ABD212) into place on the outer side of the first and last glazing bar.

ABD212

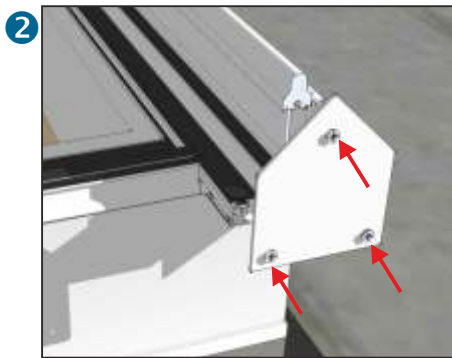

- Screw fix glazing bar end caps (ABD316 or ABD317 depending on glazing bar used).
- Silicone screws and joins to keep water tight.



- Continue fixing process until all end caps are fitted.

# Step Five

## Glazing



- Start with unit one on the left hand side.
- Place end trim on one end of the unit.
- Rest back section (with the end trim) onto the rafters tight to the end caps.

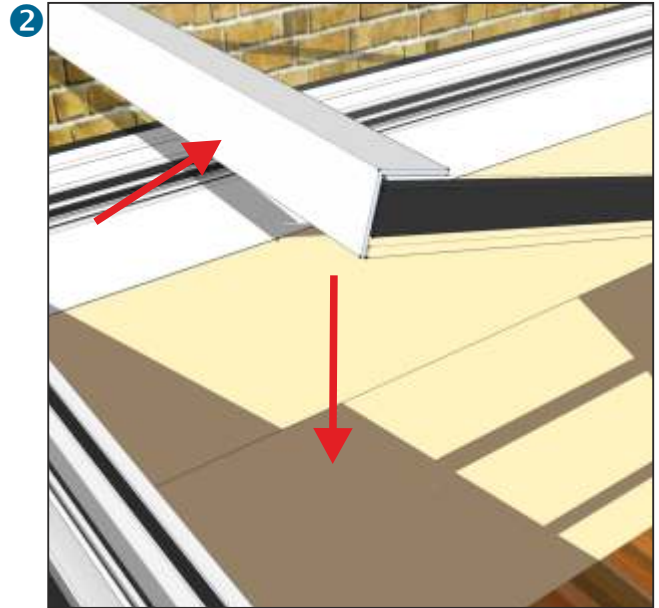

- While the glazed unit is in this position apply the end trim (ABD140) to the other edge of the glazed unit.
- Place glazed unit with end trim down onto the rafters. The unit & trim will sit behind the end caps which holds it in position.

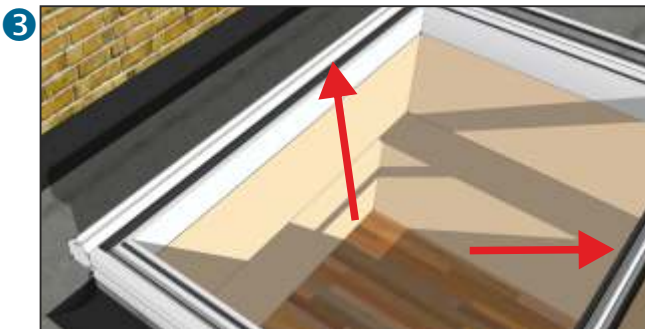

- Snap glazing beads (ABD210) to each side of the unit.
- Please note all gaskets that seal against the glass will be pre inserted in our factory.



- Repeat the glazing steps for each pane of glass until the roof is completed.

**For openers please see page 7 for installation and glazing procedure.**

# Roof Vents

## Installing A Roof Vent

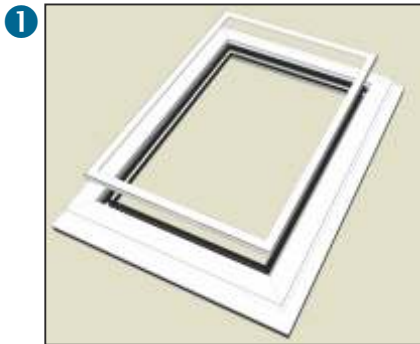

- 1**
- Roof vent/s will come pre-assembled and unglazed.
  - Step one remove beads.
  - Please seal all joints on site for weather tightness.



- 2**
- Slip the two transoms into position on the vent.
  - These go to the top and bottom.

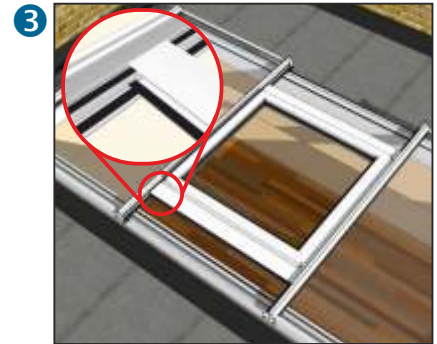

- 3**
- Glazing bars are pre-prepared for the transoms to sit flush
  - Bed transoms down with silicone onto glazing bar.

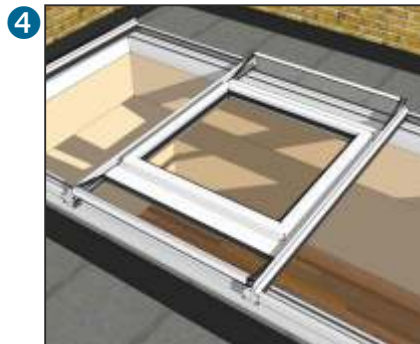

- 4**
- Insert glazed units into the transoms at the top & bottom with the end caps.
  - Bead each side as normal.  
(This secures the vent, top & bottom glazed unit in place)
  - Gaskets used to seal against the glass / vent will be pre inserted in our factory.

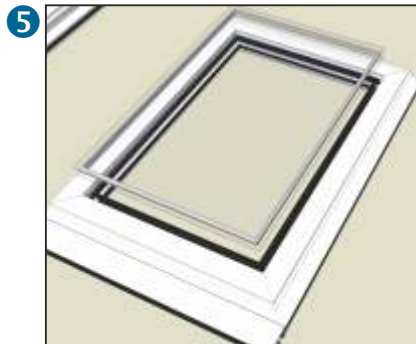

- 5**
- Insert glazed unit into roof vent.

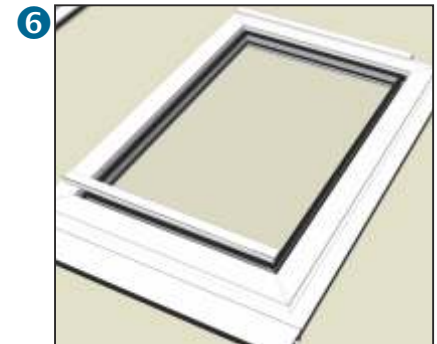

- 6**
- Snap top and bottom beads into place.

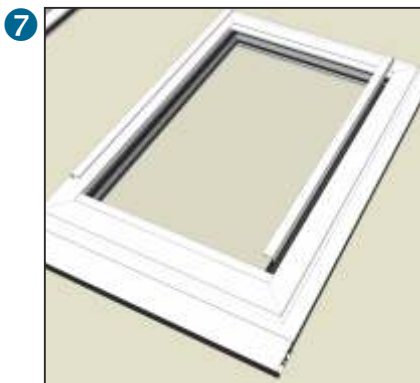

- 7**
- Snap side beads into place.

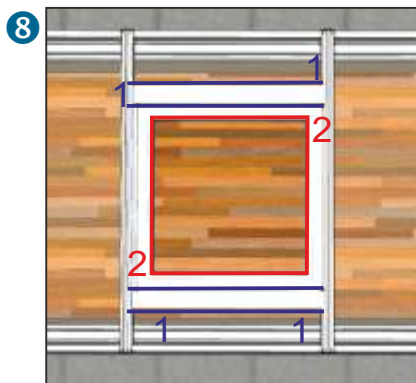

- 8**
- Gasket all components.
  - 1: use ABD305 (or ABD304)
  - 2: use ABD302 (or ABD301)



- 9**
- Once installed continue glazing the rest of the roof.

### **Main Office & Factory**

Units 4-5,                    t: 01268 681612 (15 lines)  
Charfleets Road,        f: 01268 510058  
Canvey Island,         e: [sales@duration.co.uk](mailto:sales@duration.co.uk)  
Essex. SS8 0PQ        w: [www.duration.co.uk](http://www.duration.co.uk)

### **Grand Design Exhibition Centre**

Unit 1 Casino Parade,    t: 01268 695100  
Eastern Esplanade,  
Canvey Island,         SatNav Directions  
Essex. SS8 7FJ         Use: SS8 7DN.