







DURATION WINDOWS

Horizontal Sliding Secondary Glazing Economy Odd Leg System Section Identification

Contents

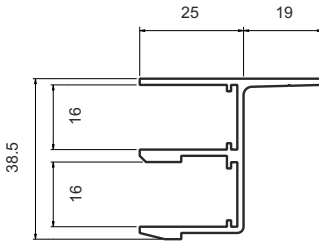
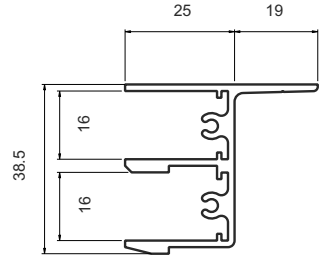
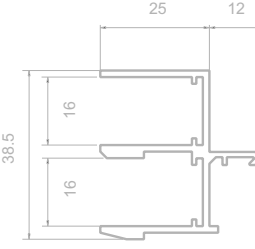
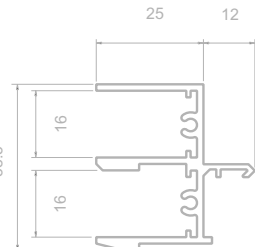
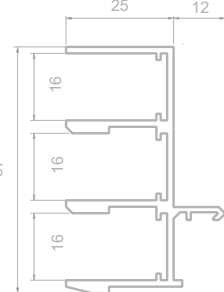
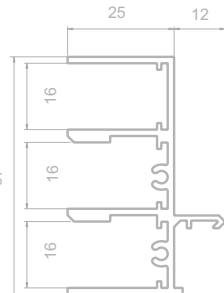
- Section Identification Overview Page 2
- Outerframes Page 3
- Sliding Panels Page 4
- Non-Aluminium Parts Page 6
- Two Pane Secondary Glazing Page 7
- Three Pane Secondary Glazing Page 8
- Four Pane Secondary Glazing Page 10
- Five Pane Secondary Glazing Page 12

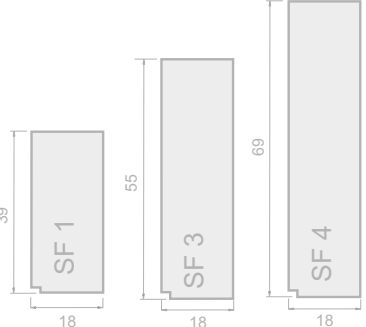
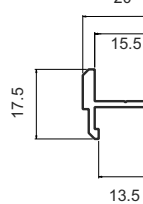
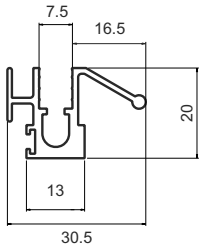
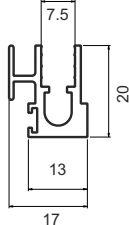
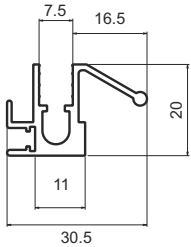
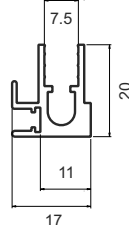
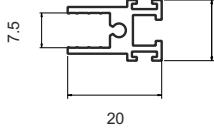
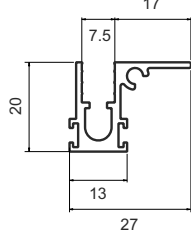
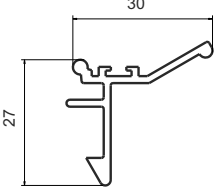
Overview

<p>Economy Outerframe</p> <p>SG 91 Odd Leg Outerframe no screw ports</p>  <p>38.5 16 25 19</p> <p>SG 92 Odd Leg Outerframe with screw ports</p>  <p>38.5 16 25 19</p>	<p>Subframe Outerframe</p> <p>SG 52 Subframe Fix Outerframe no screw ports</p>  <p>38.5 16 25 12</p> <p>SG 53 Subframe Fix Outerframe with screw ports</p>  <p>38.5 16 25 12</p>	<p>Triple Track Outerframe</p> <p>SG 85 Subframe Fix Outerframe no screw ports</p>  <p>57 16 25 12</p> <p>SG 86 Subframe Fix Outerframe with screw ports</p>  <p>57 16 25 12</p>
<p>Non-Aluminium Parts</p> <p>SG 55 PVCU Track</p>  <p>39 18 55 69</p> <p>SF 1 SF 3 SF 4</p> <p>Wooden Suframe</p> 	<p>Sliding Panel Frame Interlocks</p> <p>SG 58 Meeting Stile Interlock</p>  <p>17.5 13.5 20 15.5</p> <p>SG 59 Interlock with handrail</p>  <p>30.5 13 7.5 16.5 20</p> <p>SG 60 Interlock</p>  <p>17 13 7.5 20</p> <p>SG 61 Interlock with handrail</p>  <p>30.5 11 7.5 16.5 20</p> <p>SG 62 Interlock</p>  <p>17 11 7.5 20</p>	
<p>Sliding Panel Frame & Locking Catch</p> <p>SG 64 Sliding panel horizontals</p>  <p>7.5 20 13</p> <p>SG 71 Sliding Panel handle section with handrail</p>  <p>20 13 7.5 17 27</p> <p>SG 57 Sprung loaded finger latch</p>  <p>27 30</p> <p>Nylon Skids</p> 		

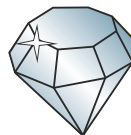

Outerframe

SG 91
Odd Leg Outerframe
no screw ports

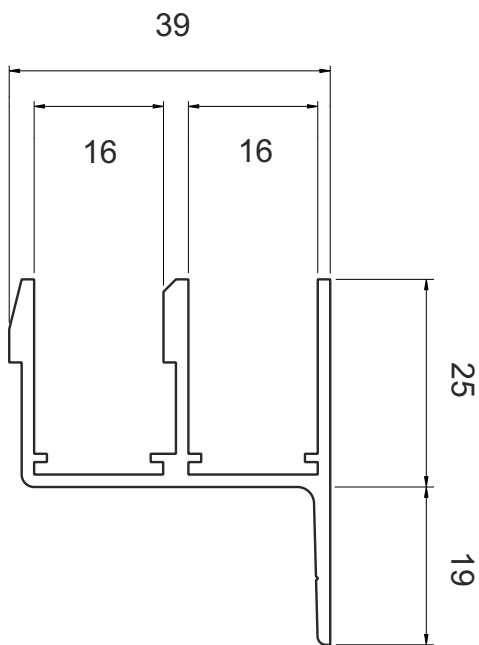

SG 92
Odd Leg Outerframe
with screw ports

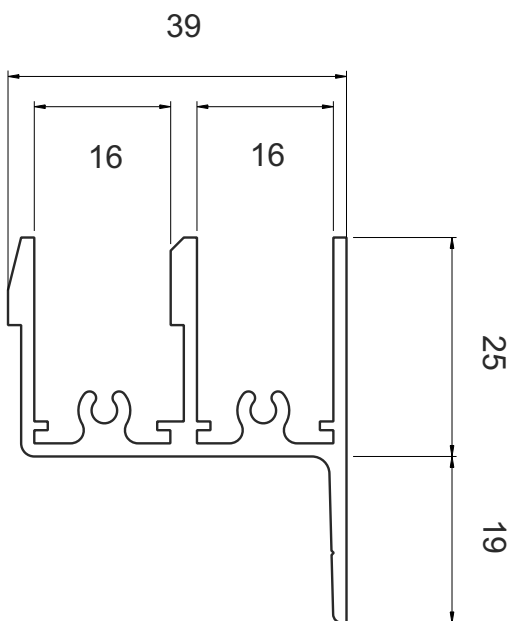



Sliding panels

SG 57
Sprung loaded
finger latch

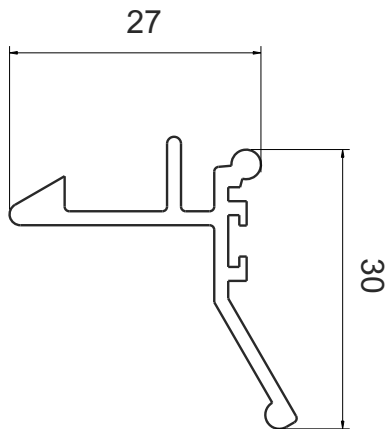

SG 58
Meeting Stile
Interlock

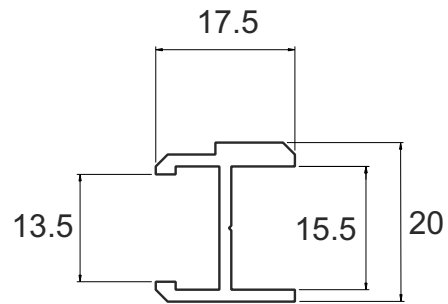

SG 59
Interlock
with handrail

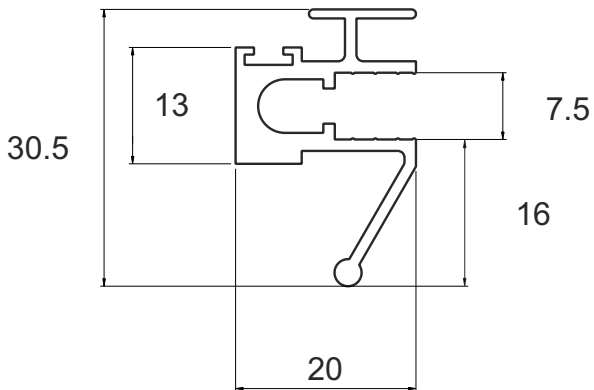

SG 60
Interlock

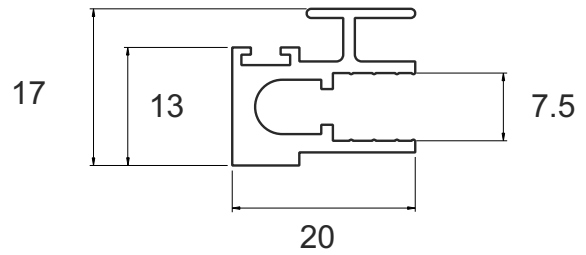



Sliding panels

SG 61
Interlock
with handrail

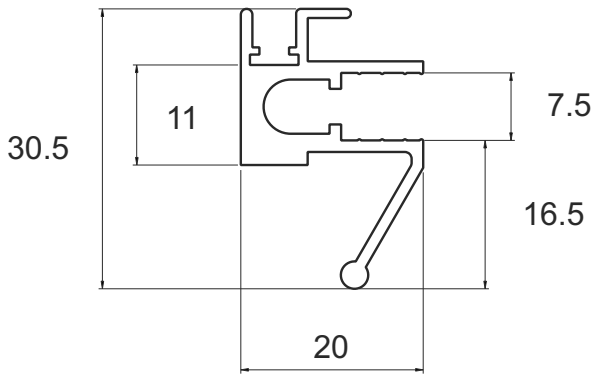

SG 62
Interlock

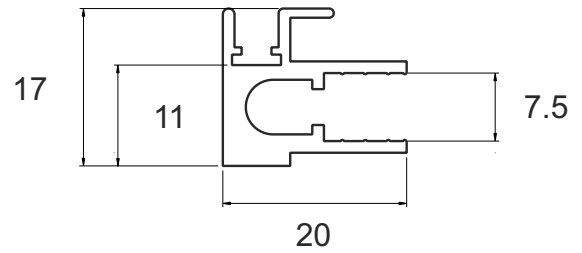

SG 64
Sliding panel
horizontals

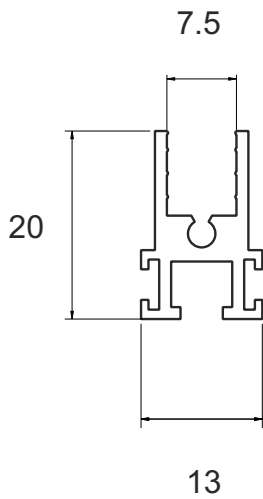

SG 71
Sliding Panel
handle section
with handrail

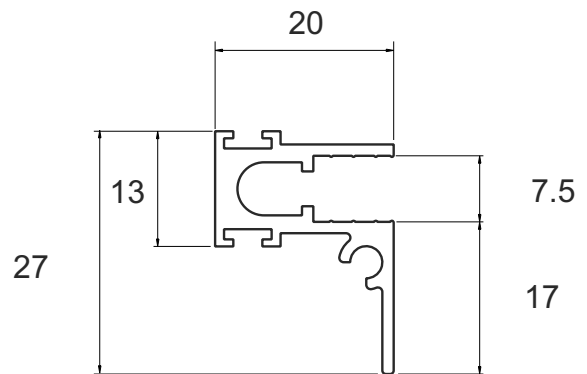



Non-Aluminium Parts

SG 55
PVCU Track

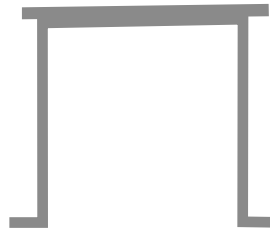

Nylon Skids





Two Pane Horizontal Slider

Economy Odd Leg

A - Left Jamb

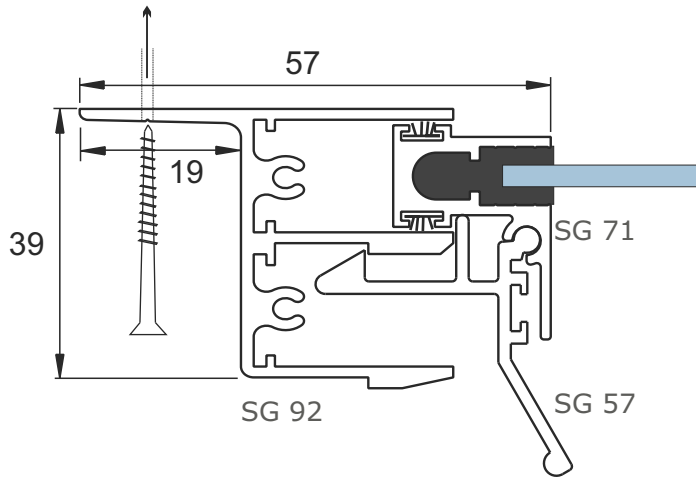

B - Interlock

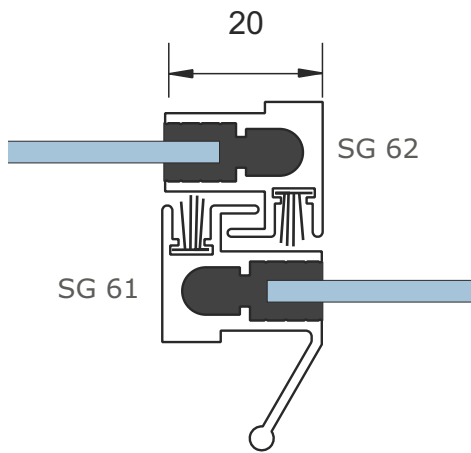

C - Right Jamb

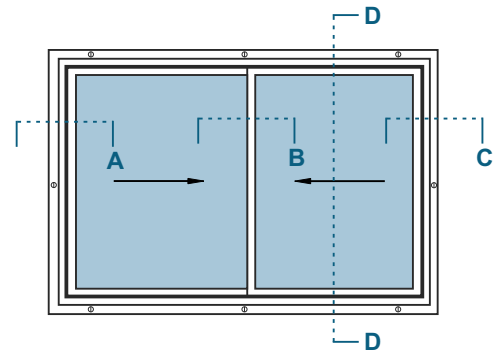
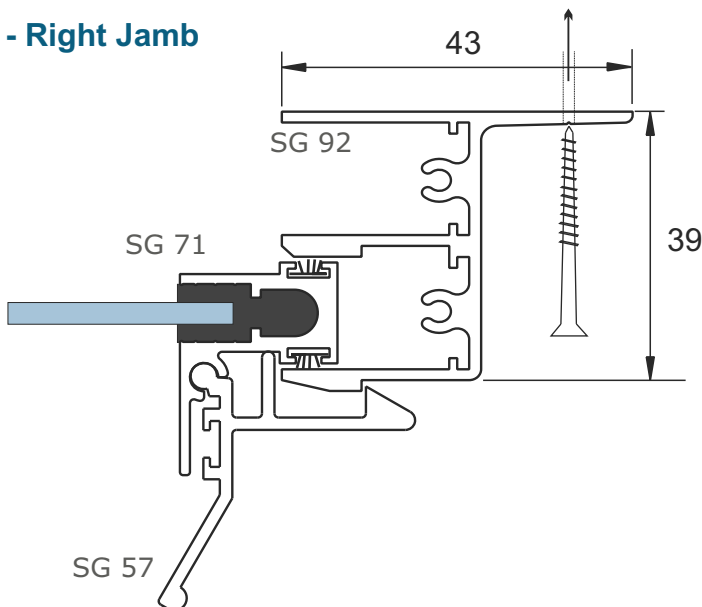

D - Cross Section

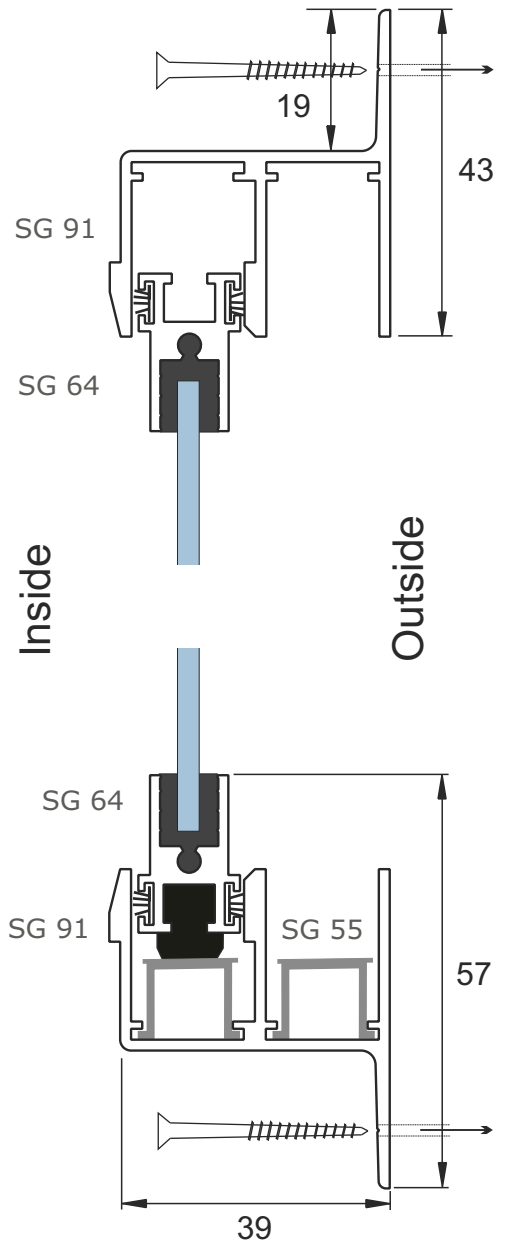



Three Pane Horizontal Slider - Fixed Middle Panel

Economy Odd Leg

A - Left Jamb

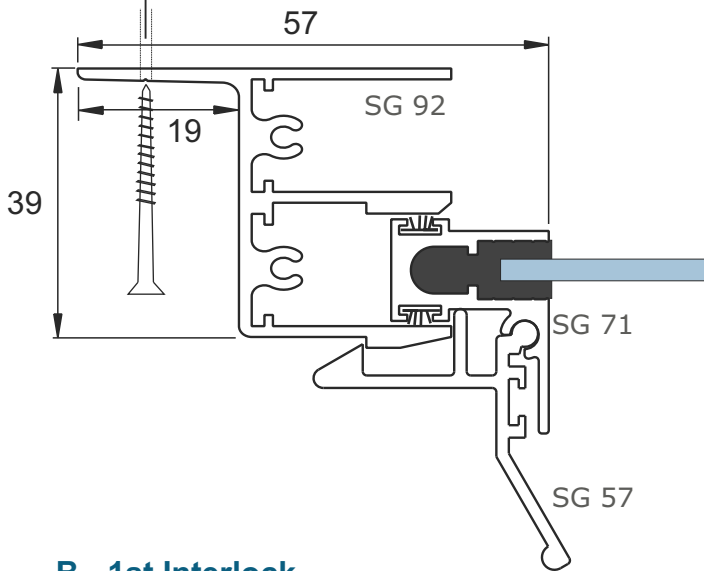

B - 1st Interlock

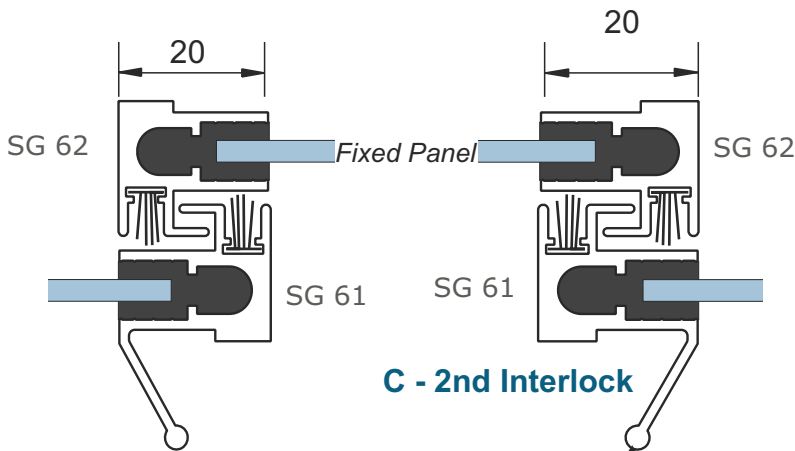

C - 2nd Interlock

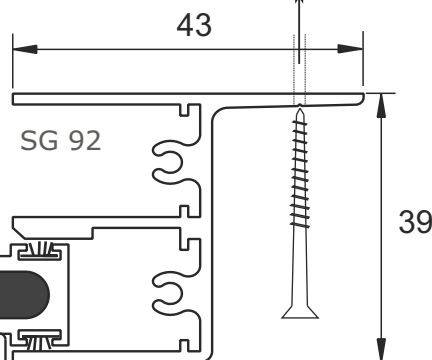

D - Right Jamb

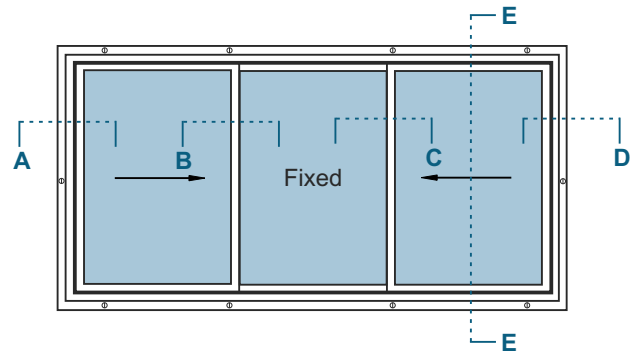
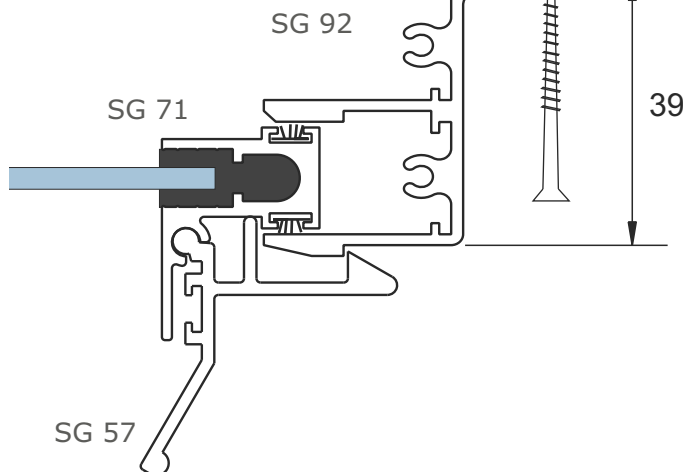

E - Cross Section

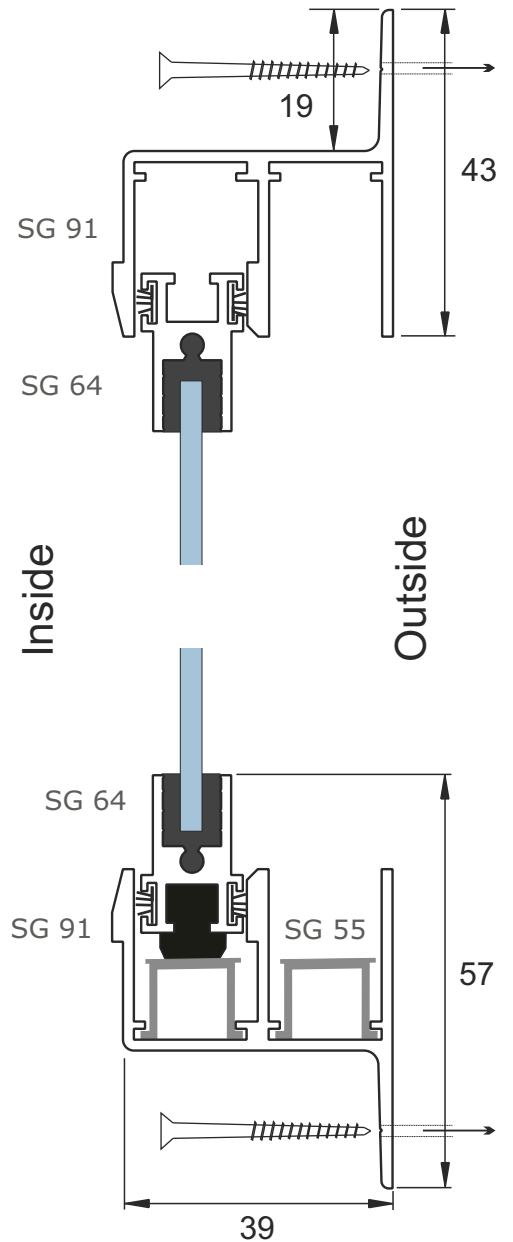



Three Pane Horizontal Slider - All Sliding

Economy Odd Leg

A - Left Jamb

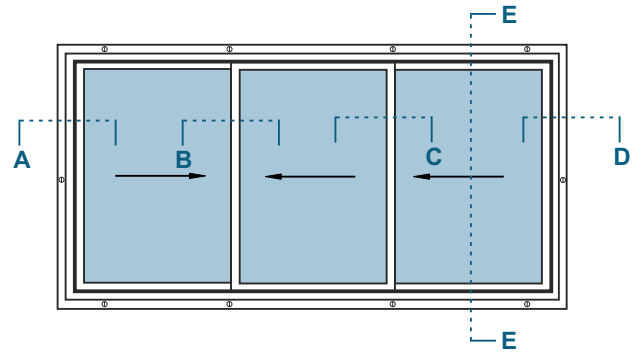
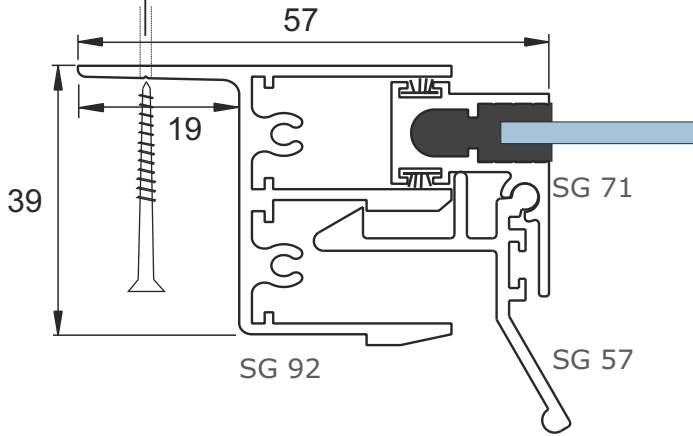

E - Cross Section

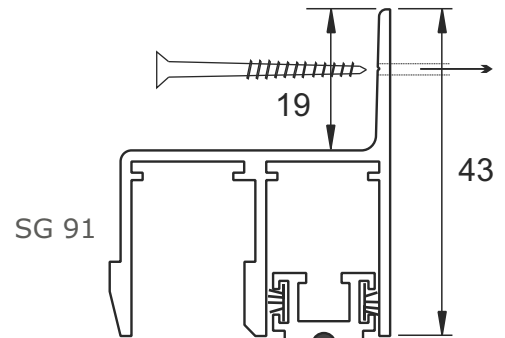

B - 1st Interlock

C - 2nd Interlock

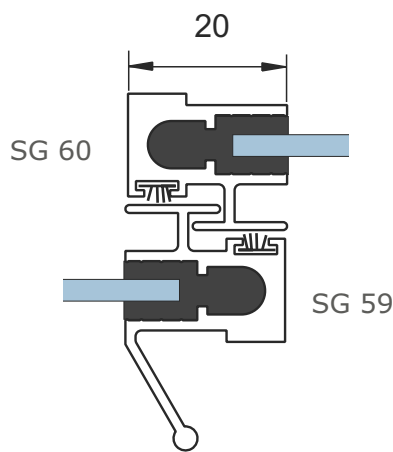
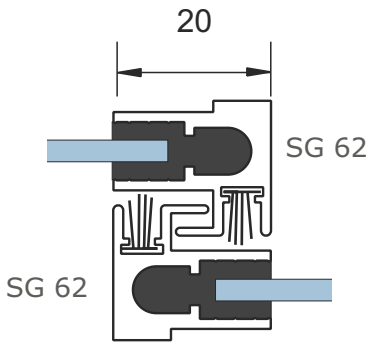

Inside
Outside

D - Right Jamb

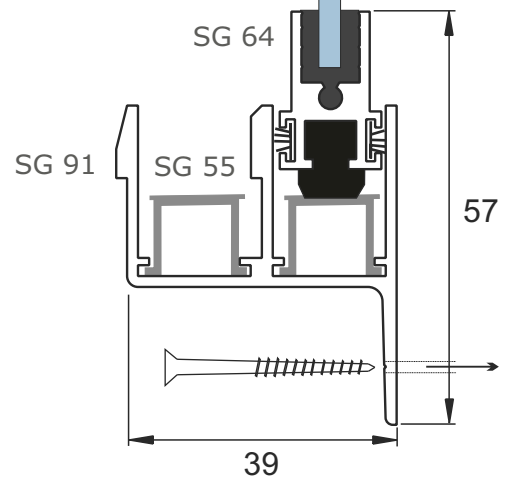
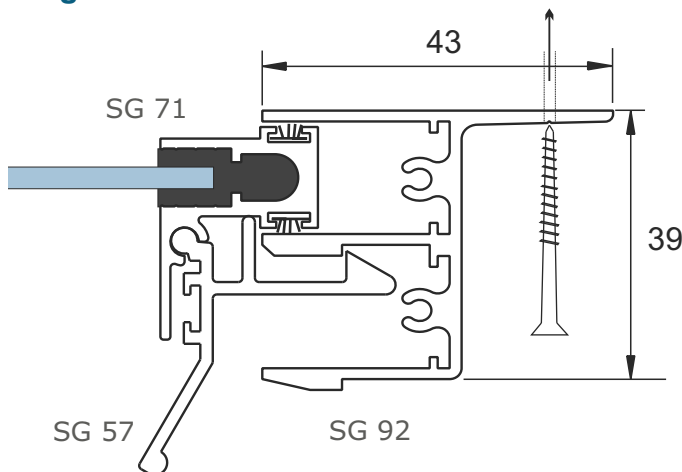



Four Pane Horizontal Slider

Economy Odd Leg

A - Left Jamb

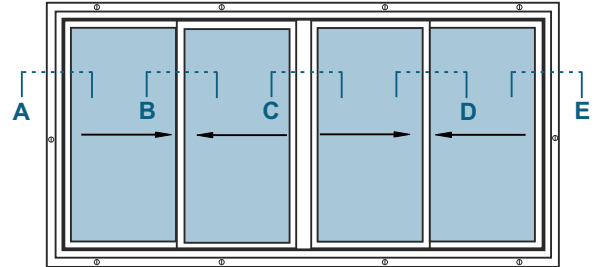
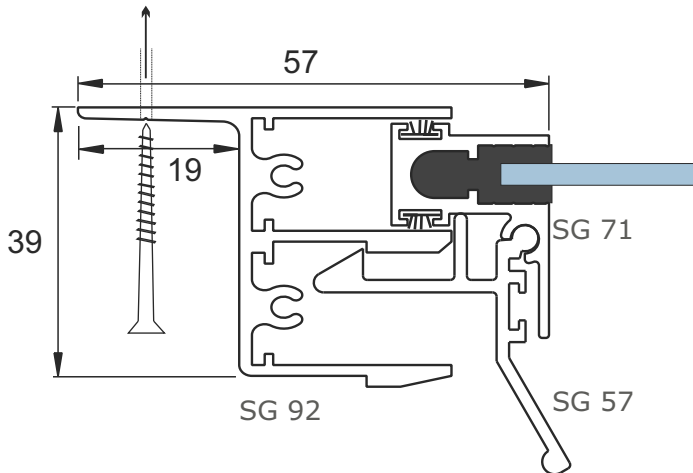

B - 1st Interlock

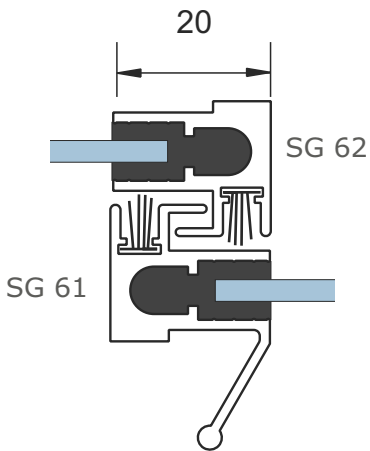

C - Meeting Stile

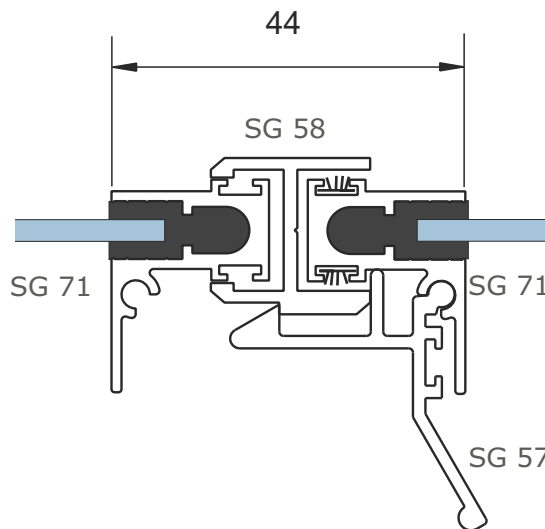

D - 2nd Interlock

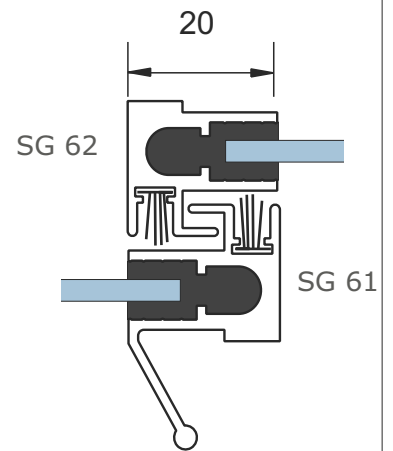

E - Right Jamb

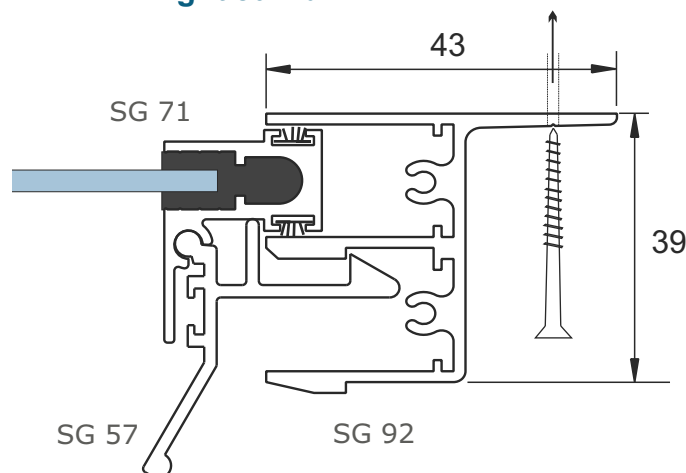



Four Pane Horizontal Slider

Economy Odd Leg

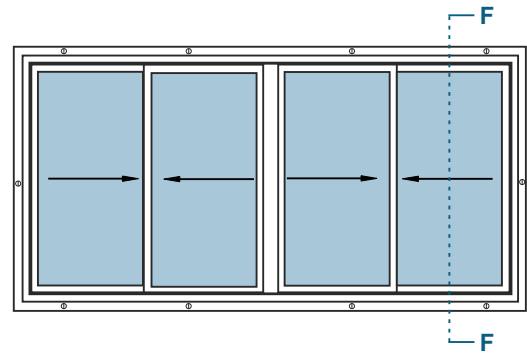

F - Cross Section

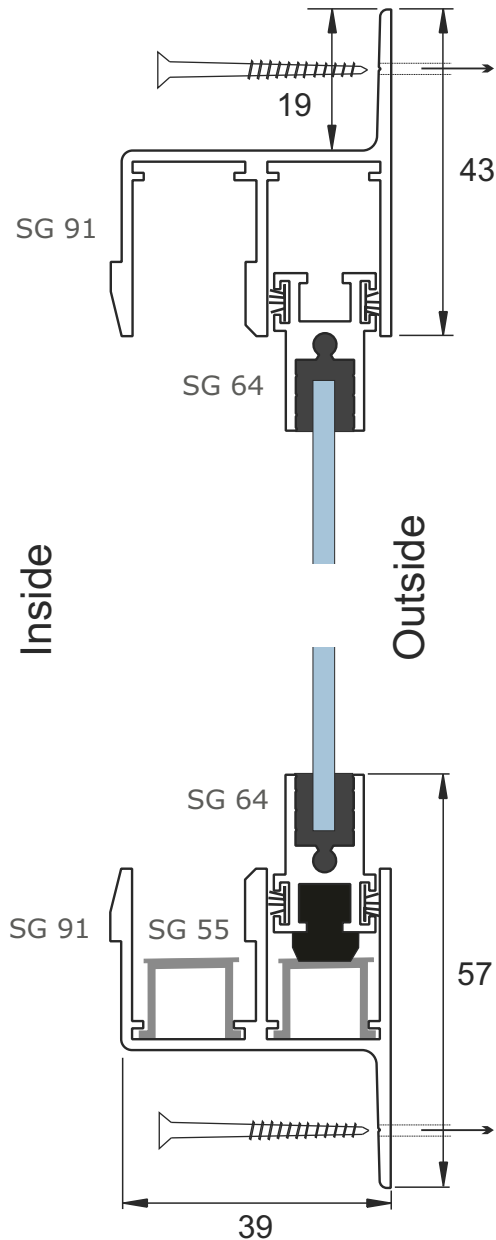



Five Pane Horizontal Slider

Economy Odd Leg

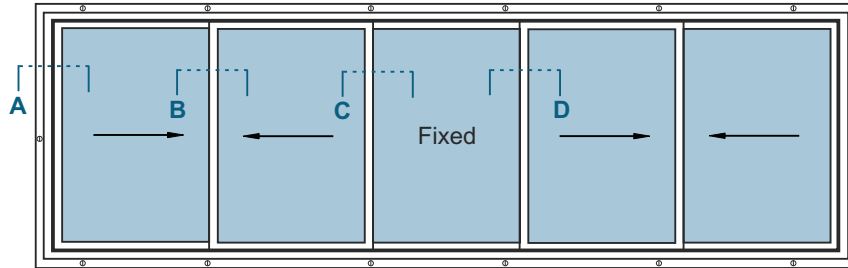

A - Left Jamb

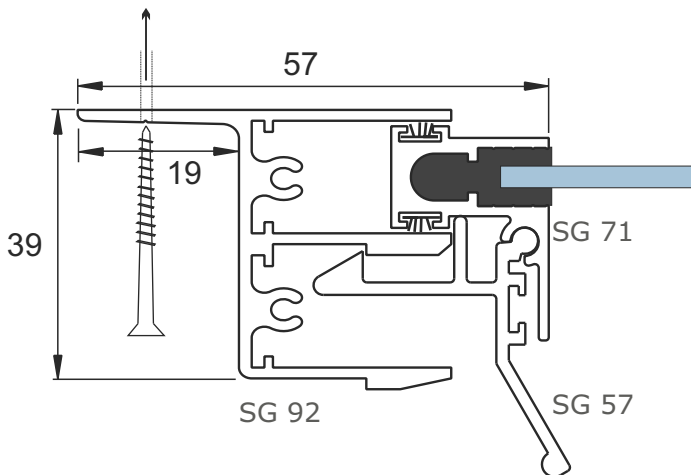

B - 1st Interlock

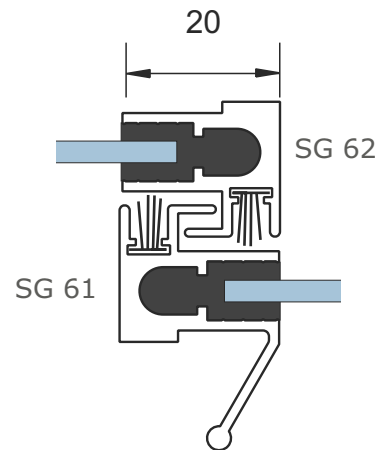

C - 2nd Interlock

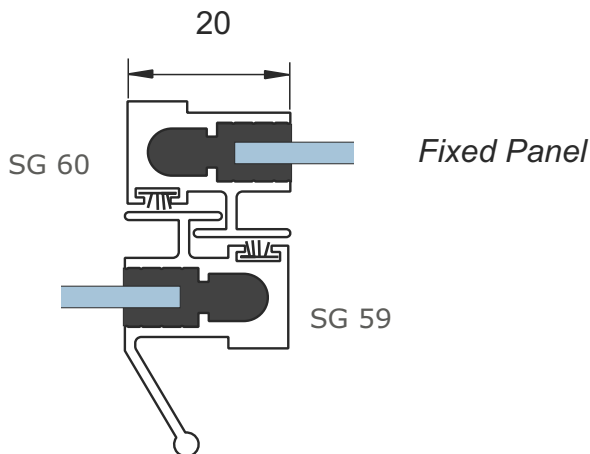

D - 3rd Interlock

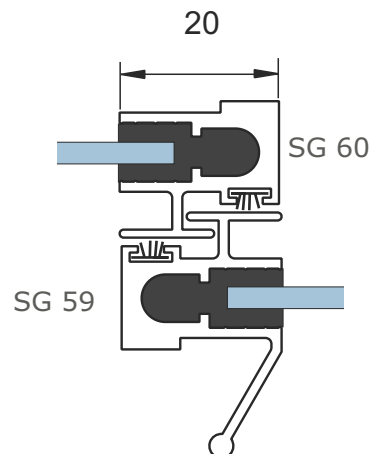



Five Pane Horizontal Slider

Economy Odd Leg

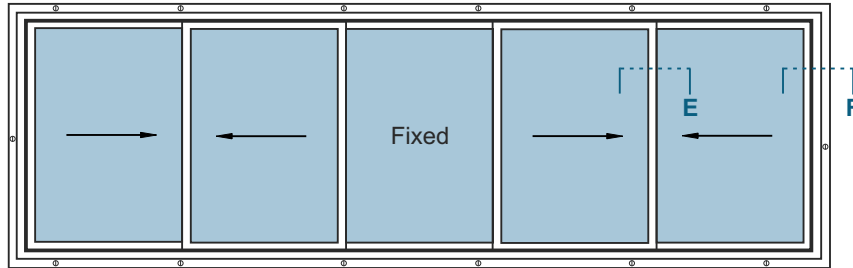

E - Last Interlock

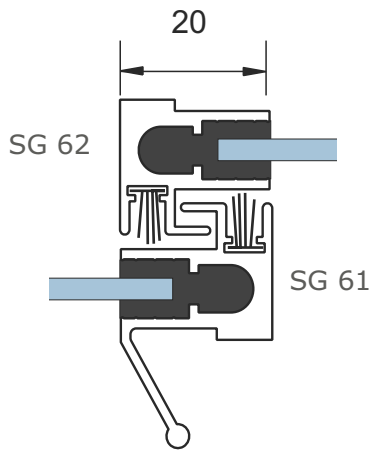

F - Right Jamb

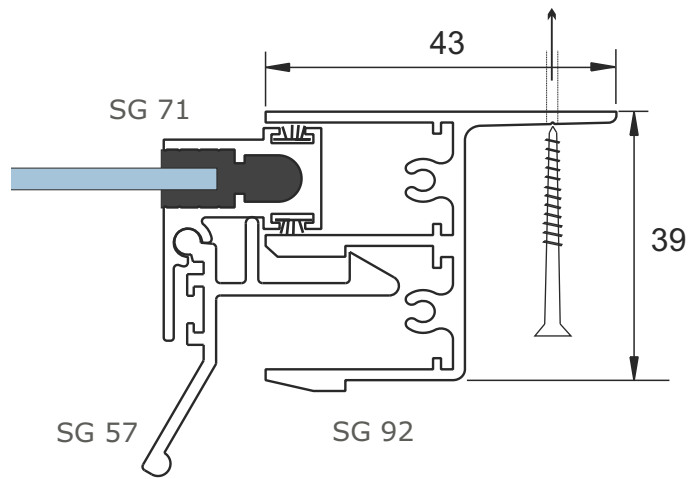



Five Pane Horizontal Slider

Economy Odd Leg

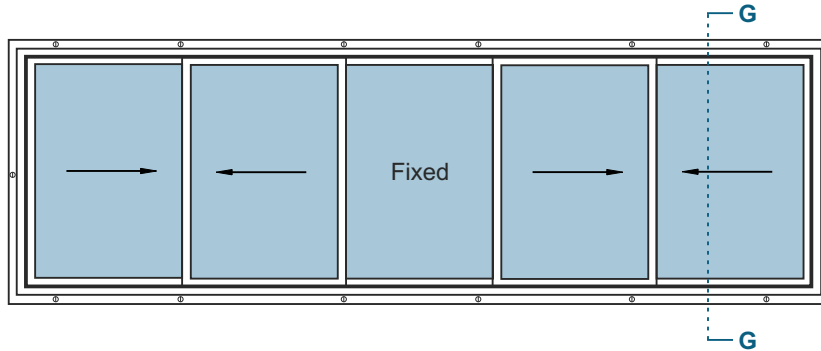

G - Cross Section

