

# Smarts Ali47

Aluminium Windows

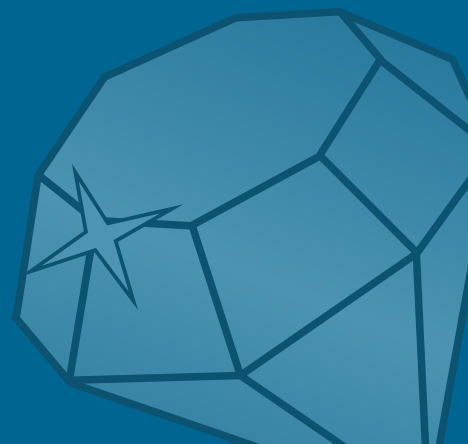

DURATION  
WINDOWS



# *Slim* & Stylish **Aluminium Windows**



Our Ali 47 Windows are very popular, and offer everything you would expect from a quality aluminium window. The inherent strength of the aluminium means the frame is slimmer than PVCu or timber, letting the maximum amount of light into your home. These windows are available in a wide choice of finishes and colours, including dual colours and are now also available with our innovative Chelton® Handle range.

These residential aluminium windows use high quality double glazed sealed units and 'Polyamide' thermal break technology keeping your home warm, quiet and comfortable all year round. They meet all the latest requirements for new build, replacement and refurbishment projects, and provide excellent weather performance.

## Key Features

- High performance windows at an affordable price.
- Conventional DUR colour range - White, Black, Dark Grey 7016, Medium Grey, Silver Grey, Cream or Brown.
- Available in any of over 200 single or dual RAL colours.
- Range of textured colours also available.
- 'Polyamide' thermally broken profiles for energy efficiency.
- Hardware available in a range of colours including our exclusive Chelton Handle range.
- Can be supplied unglazed or glazed for 28mm or 24mm units.
- Internally or externally beaded options available.\*
- Range of styles available to suit every application.
- Exceeds current building regulations for Doc L.
- Suitable for commercial or domestic projects.
- Matches our Ali47 Residential doors.



## Options

- Choice of 6 outerframes.
- 47mm or 70mm outerframe depths.
- Choice of 7 different sash designs.
- White, light grey or black gaskets available.
- Range of projection cills available to suit your build.
- Hardwood frames available if required.

\*Fixed windows are always externally beaded.

# Ali47 Window

Our Ali47 windows come with a range of options so that they can be customised to suit your design needs.

These windows are perfect for new builds, refurbishment or replacement projects and can be designed to co-ordinate with our other aluminium products such as bi-folding doors, patio doors or Single or French residential doors.

## Sash Options

*Chelton Vent*

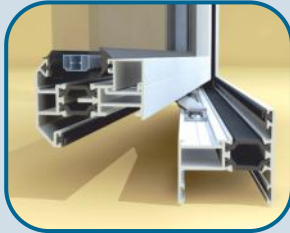

*Feature Vent*



*Flat Security Vent*



*Ovolo Vent*



*Ovolo Feature Vent*

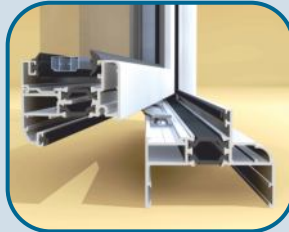

*Flat Vent*



*Cockspur Vent*



Please consult our website for more options and details.

## Security

Our Ali47 windows are equipped with a range of security features including:

- Modern multi-point shootbolt locking with key locked Espag handles or multi-point Chelton Secure with key locked Chelton Handles.
- Sash jammers to hinge side.
- Night vent security as standard.
- Modern friction hinges.
- Optionally upgrade to laminated glass for extra security.

## Performance

Our Ali47 are designed with performance in mind to create the best windows possible at an affordable price.

WER



Air Permeability



Water Tightness



Wind Resistance



Ali47 Windows & Matching Doors



Range Of Styles Including Bays



Available In 200+ Colours

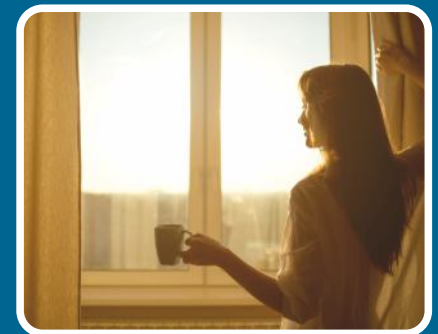

Slim, Stylish & Efficient



Range Of Styles & Options

# Curved & Shaped Windows

The Ali47 can be fabricated in a range of triangular, semi-circular or circular fixed frame windows. These can be used in a range of applications and can be coupled to our doors to create a light and airy space.

## Curved Products

- Circular, Semi-circular or Gothic arched windows available.
- Curved products must have true curves.
- Smallest diameter achievable is 600mm.
- Fixed windows only (non opening).
- 70mm or 47mm frame options (ETC018 or ETC012).
- Shaped products use a chamfered clip in bead only.
- Shaped windows can be coupled with most door ranges.

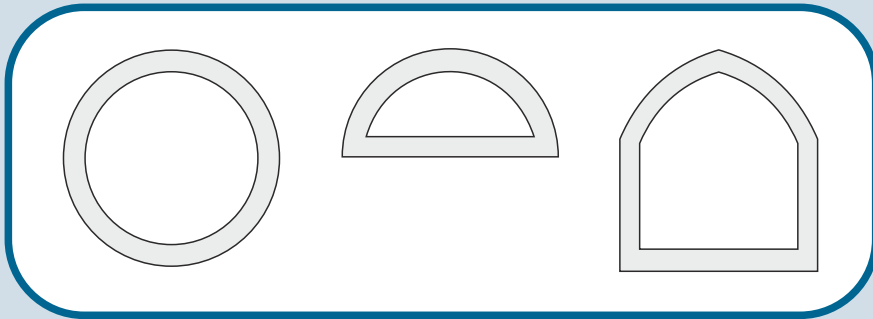

## Shaped Products

- Shaped windows are fixed only, non opening only.
- Shaped designs include: Triangular, Octagonal or Trapeziums.
- 70mm or 47mm frame options (All frame options available).
- Shaped windows can use either square or chamfered bead.
- Shaped windows can be coupled with most door ranges.

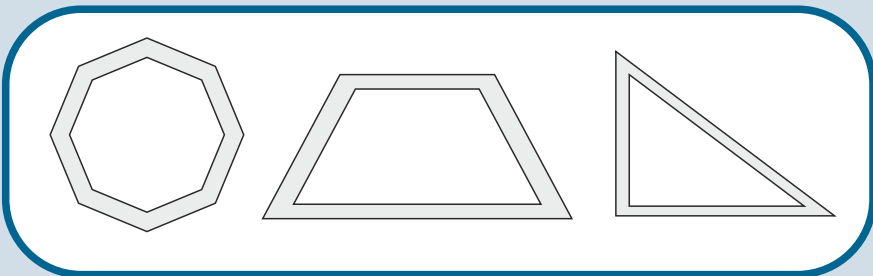

Fixed Curved Windows



Fixed Triangular Windows



Fixed Curve Top Lite

# Colours

Our Ali47 windows are available in a range of colours and can be either single or dual colour (different colour interior to exterior) to suit any design aspirations. Please see some examples below.

## DUR Colours - Flat Paint Finish

White  
(9010 G or M)



Black  
(9005 M)

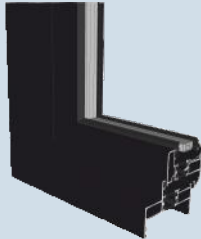

Dark Grey  
(7016 M)

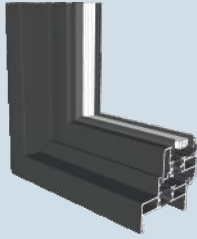

Medium Grey  
(9007 Met.)

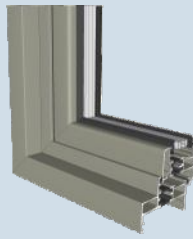

Silver Grey  
(9006 Met.)

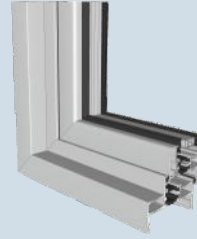

Ivory Cream  
(1015 M)

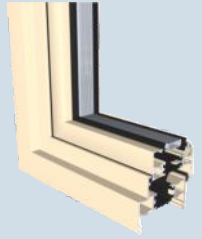

## RAL Colours

200+ RAL Colours



## Trend Colours - Textured Finish

Vulcan Black



Anthracite Grey



Available in 24 colours  
see our website.

This is only a selection of the available colours. Visit our website for more options.

Please note that for technical reasons associated with colour reproduction the images only give an indication of shade.

No guarantee can be given that they will exactly match the powder coated product.

# Glass Options

Plain  
Glass

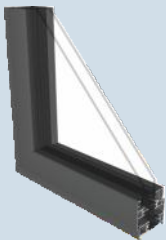

Leads  
Square, Diamond, Custom



Flat Horizontal  
Astragal Bars



Flat Overlapped  
Astragal Bars



Flat Butted  
Astragal Bars

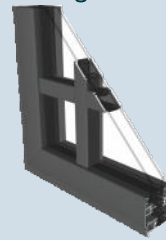

A Shaped  
Astragal Bars\*



This is only a selection of the available glass options.  
\*Only available on some configurations - please ask.

# Hardware

## Standard Handle



White Gloss  
Black  
Chrome  
Silver  
Gold

## Chelton Handles - Chelton Sash Only

Slim-Line



Art Deco



White  
Black  
Silver  
Chrome  
Gold  
Black Chrome  
Stainless Steel

Monkey Tail



White  
Black

# Technical

## Opening Windows

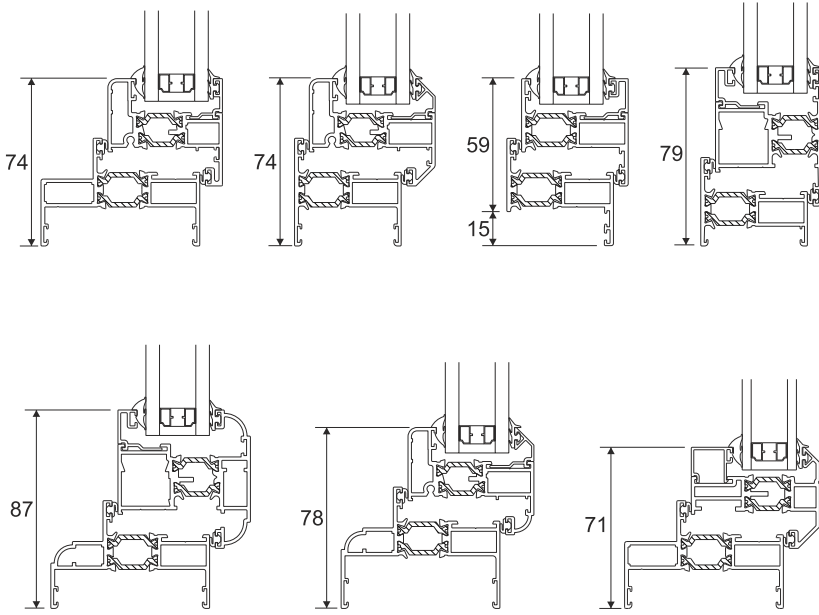

## Fixed Windows

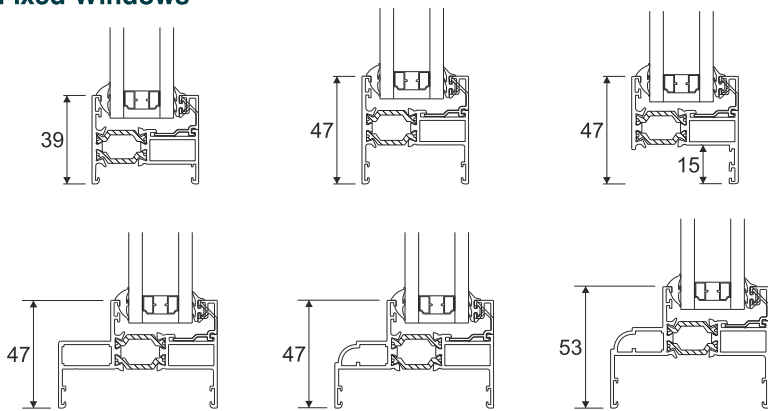

## Transom or Mullion Sections

### Fixed / Fixed

### Opener / Fixed

### Opener / Opener

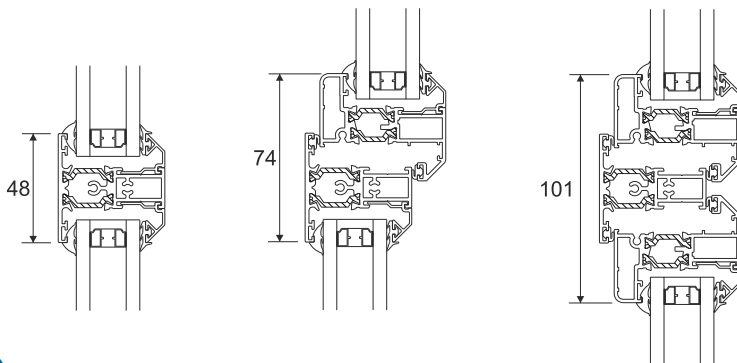

Please note this is only a sample of the technical information for this product. For the full manual please consult our website.

### **Main Office & Factory**

Units 4-5,  
Charfleets Road,  
Canvey Island,  
Essex. SS8 0PQ

t: 01268 681612 (15 lines)  
f: 01268 510058  
e: [sales@duration.co.uk](mailto:sales@duration.co.uk)  
w: [www.duration.co.uk](http://www.duration.co.uk)

### **Grand Design Exhibition Centre**

Unit 1 Casino Parade,  
Eastern Esplanade,  
Canvey Island,  
Essex. SS8 7FJ

t: 01268 695100  
SatNav Directions  
Use: SS8 7DN.