



# DURATION WINDOWS

## Durafold 1000 Folding Doors Thresholds, Floor Levels & Drainage

### Contents

• Overview		Page 2-4
• Standard Threshold	- Open Out	Page 5
	- Open In	Page 6
	- On Cill - Open Out	Page 7
	- On Cill - Open In	Page 8
• 20mm Low Threshold	- Ramp To Outside - Open Out	Page 9
	- Ramp To Outside - Open In	Page 10
	- Ramp To Inside - Open Out	Page 11
	- Ramp To Inside - Open In	Page 12
	- No Ramps - Open Out	Page 13
	- No Ramps - Open In	Page 14
	- With Cill - Open Out	Page 15
	- With Cill - Open In	Page 16
• 15mm Low Threshold	- Ramp To Outside - Open Out	Page 17
	- Ramp To Outside- Open In	Page 18
	- Ramp To Inside - Open Out	Page 19
	- Ramp To Inside - Open In	Page 20
	- No Ramps - Open Out	Page 21
	- No Ramps - Open In	Page 22
	- With Cill - Open Out	Page 23
	- With Cill - Open In	Page 24
• Threshold Drainage Paths		Page 25

**Please Note:** The sizes provided in this document need to be taken into account and included in the manufacture sizes you provide.



**Floor Levels Overview- Standard Threshold**

**Standard Threshold - Open Out**

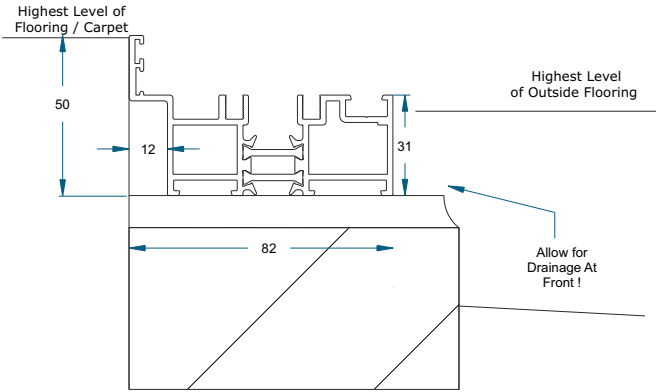

**Standard Threshold - Open In**

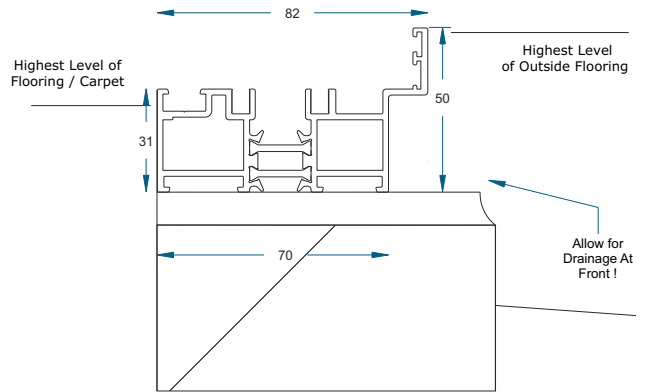

**Standard Threshold on Cill - Open Out**

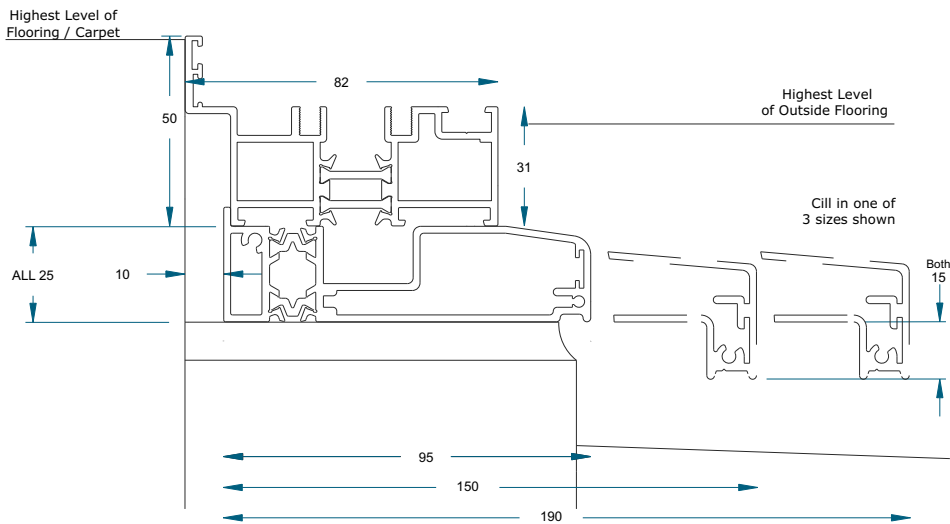

**Standard Threshold on Cill - Open In**

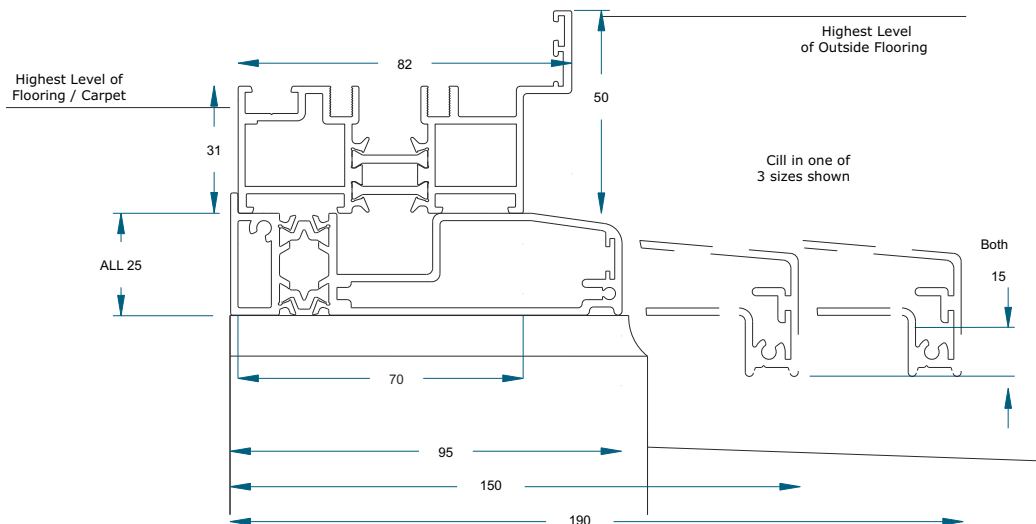

Please Note: Intended For Guidance Only - Not An Installation Drawing Or A Builder's Work Instruction



Floor Levels Overview- 20mm Low Threshold

Ramp To Outside - Open Out

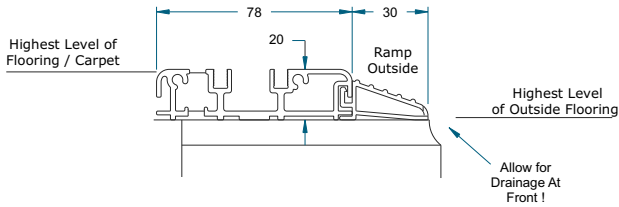

Ramp to Outside - Open In

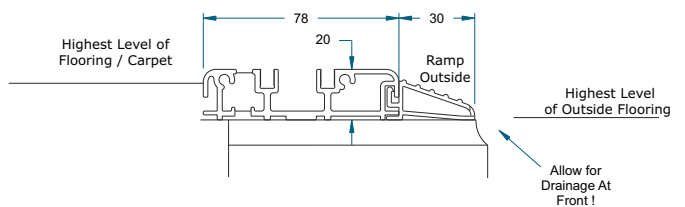

Ramp To Inside - Open Out

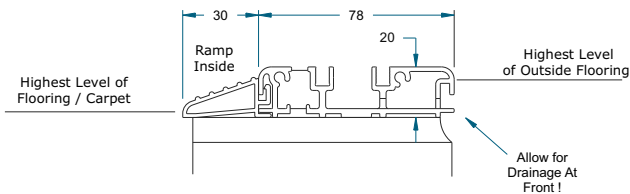

Ramp to Inside - Open In

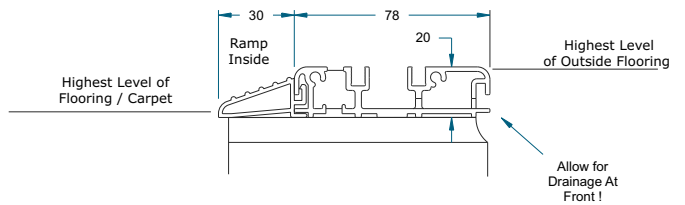

No Ramps - Open Out

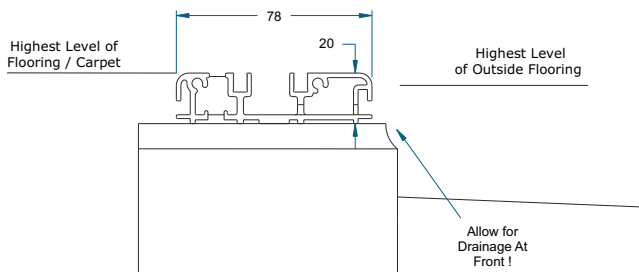

No Ramps - Open In

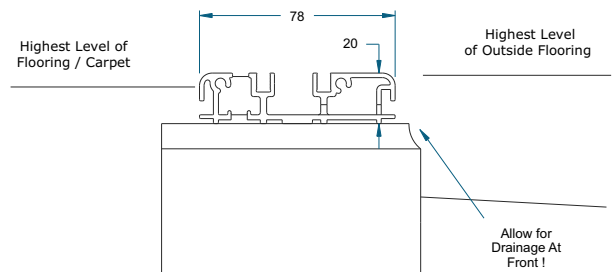

With Cill - Open Out

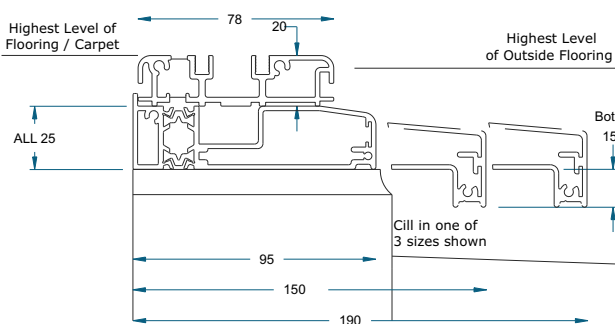

With Cill - Open In

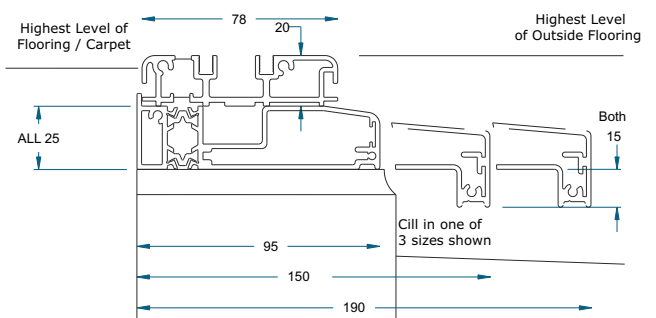

Please Note: Intended For Guidance Only - Not An Installation Drawing Or A Builder's Work Instruction



## Floor Levels Overview- 15mm Low Threshold

### Ramp To Outside - Open Out

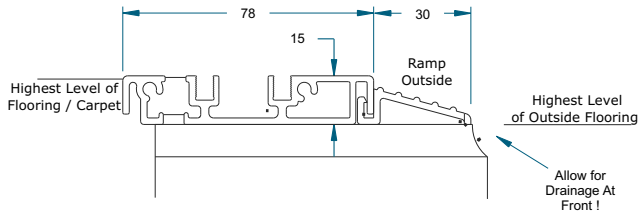

### Ramp to Outside - Open In

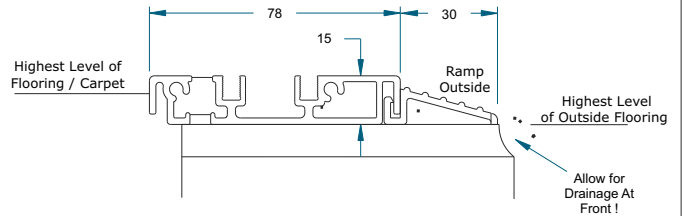

### Ramp To Inside - Open Out

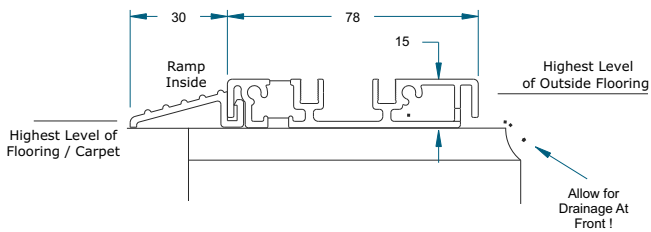

### Ramp to Inside - Open In

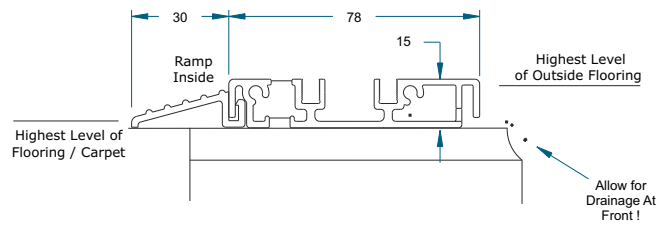

### No Ramps - Open Out

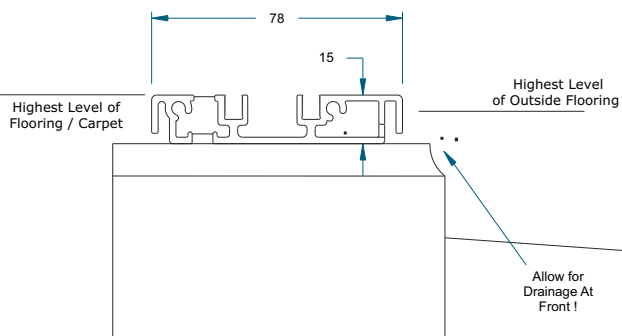

### No Ramps - Open In

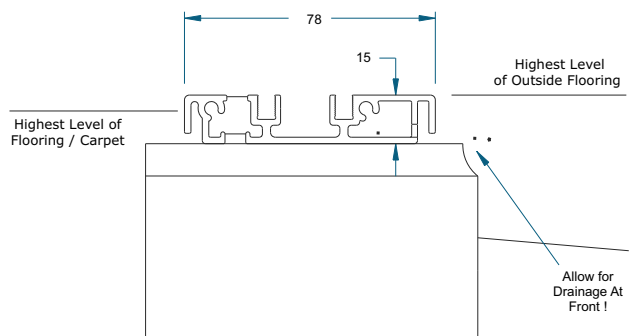

### With Cill - Open Out

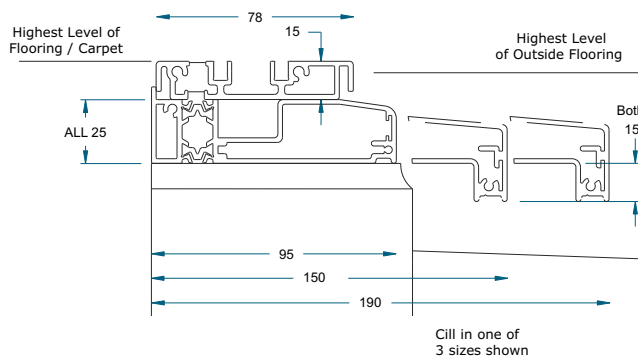

### With Cill - Open In

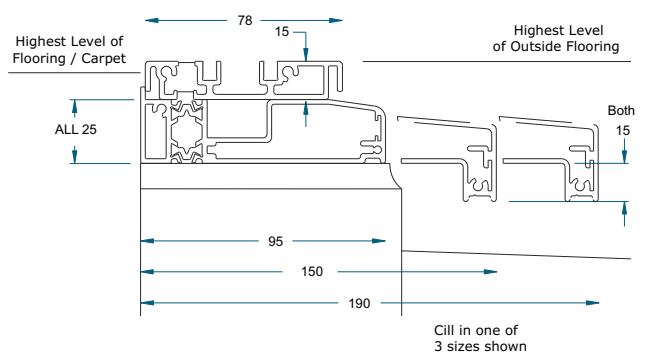

Standard Threshold - Open Out

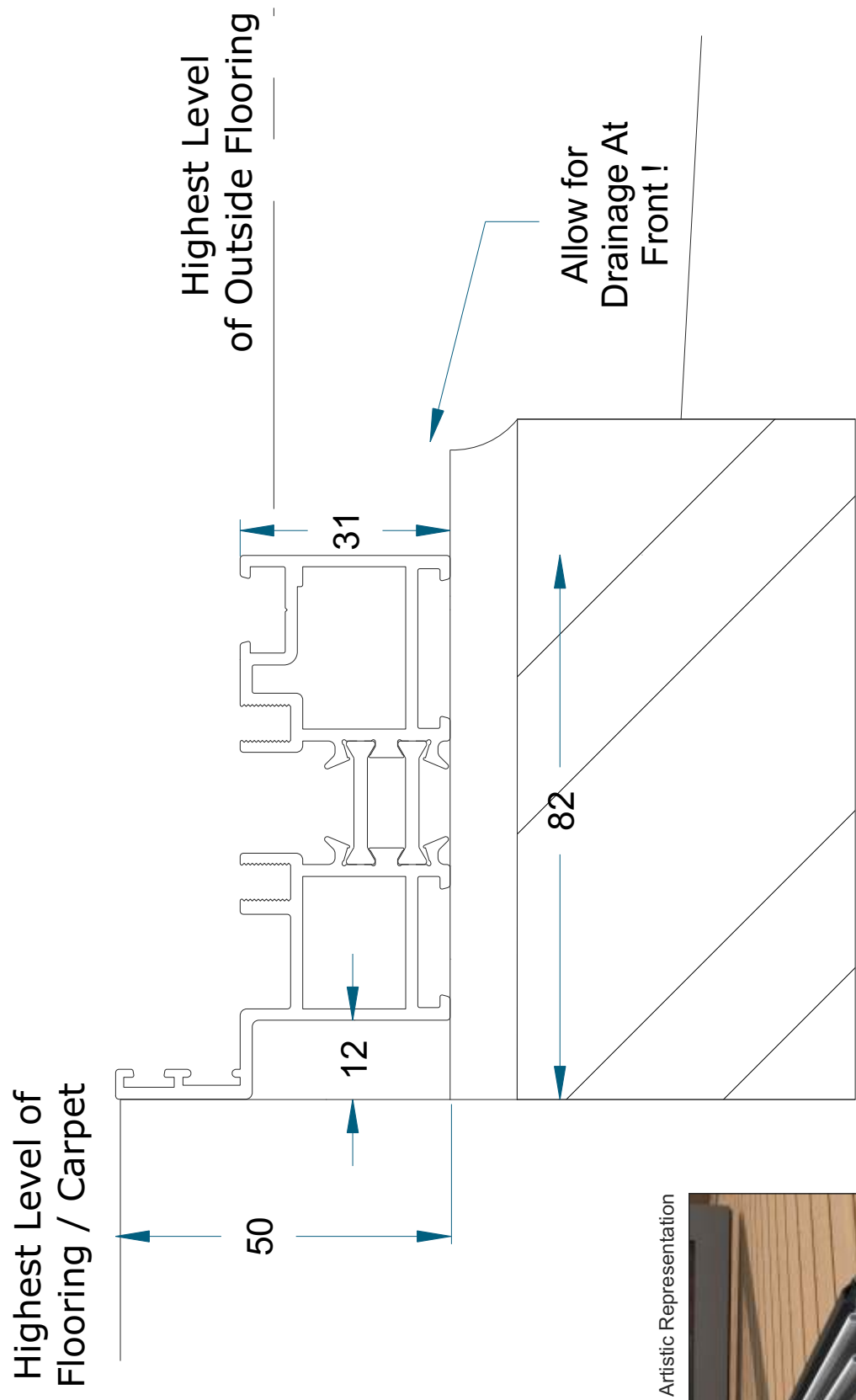

Artistic Representation



**Standard Threshold - Open In**

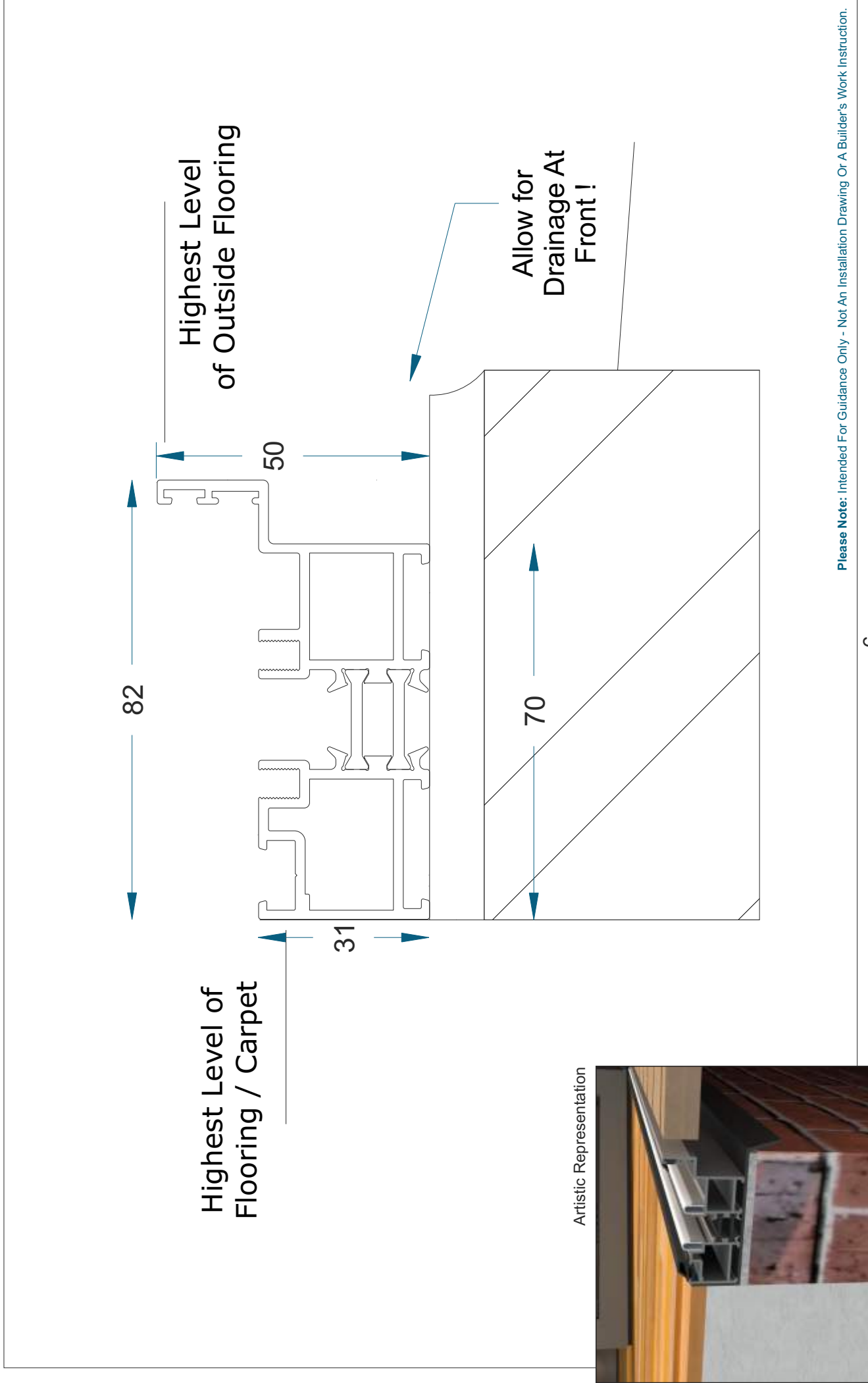

**Std Threshold On Cill - Open Out**

Highest Level of  
Flooring / Carpet

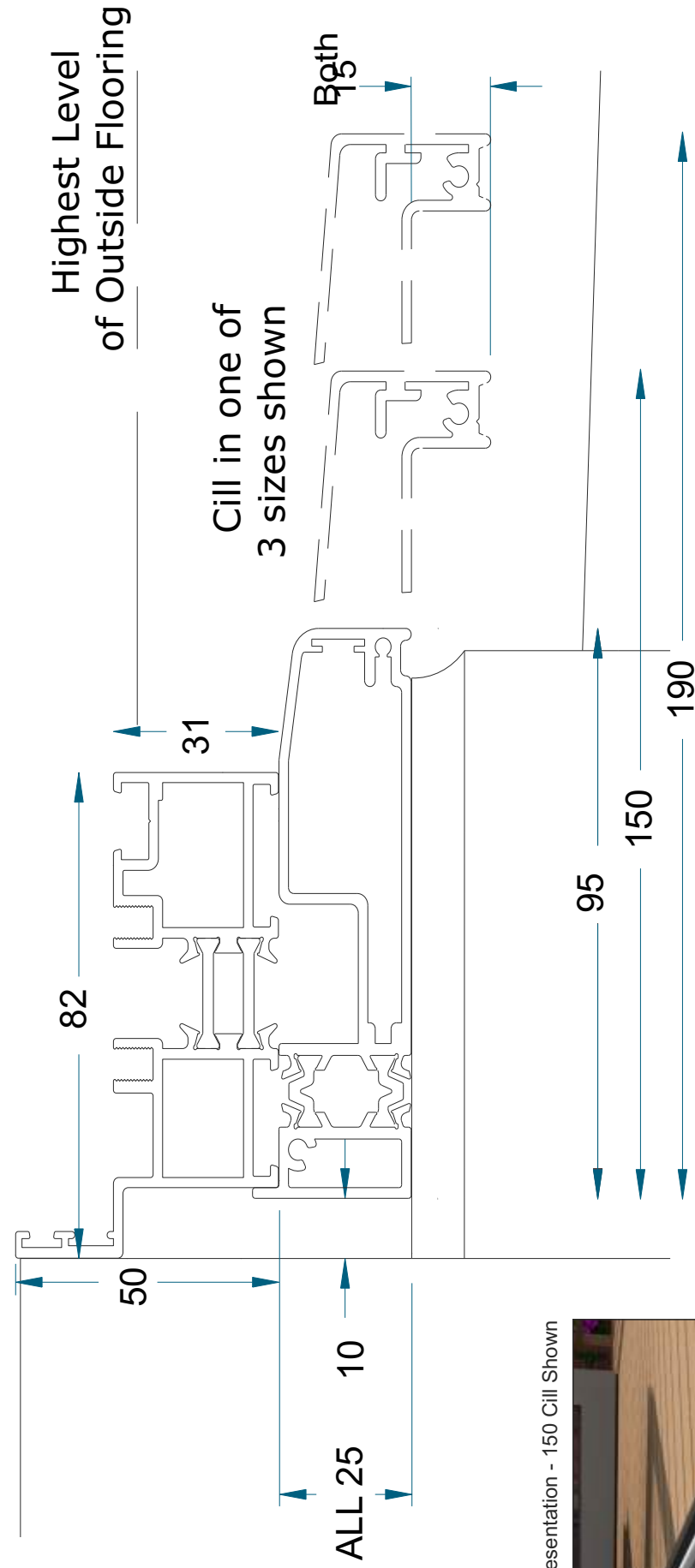

Artistic Representation - 150 Cill Shown

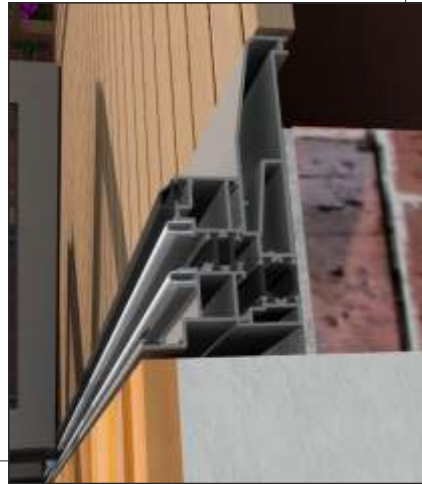

**Std Threshold On Cill - Open In**

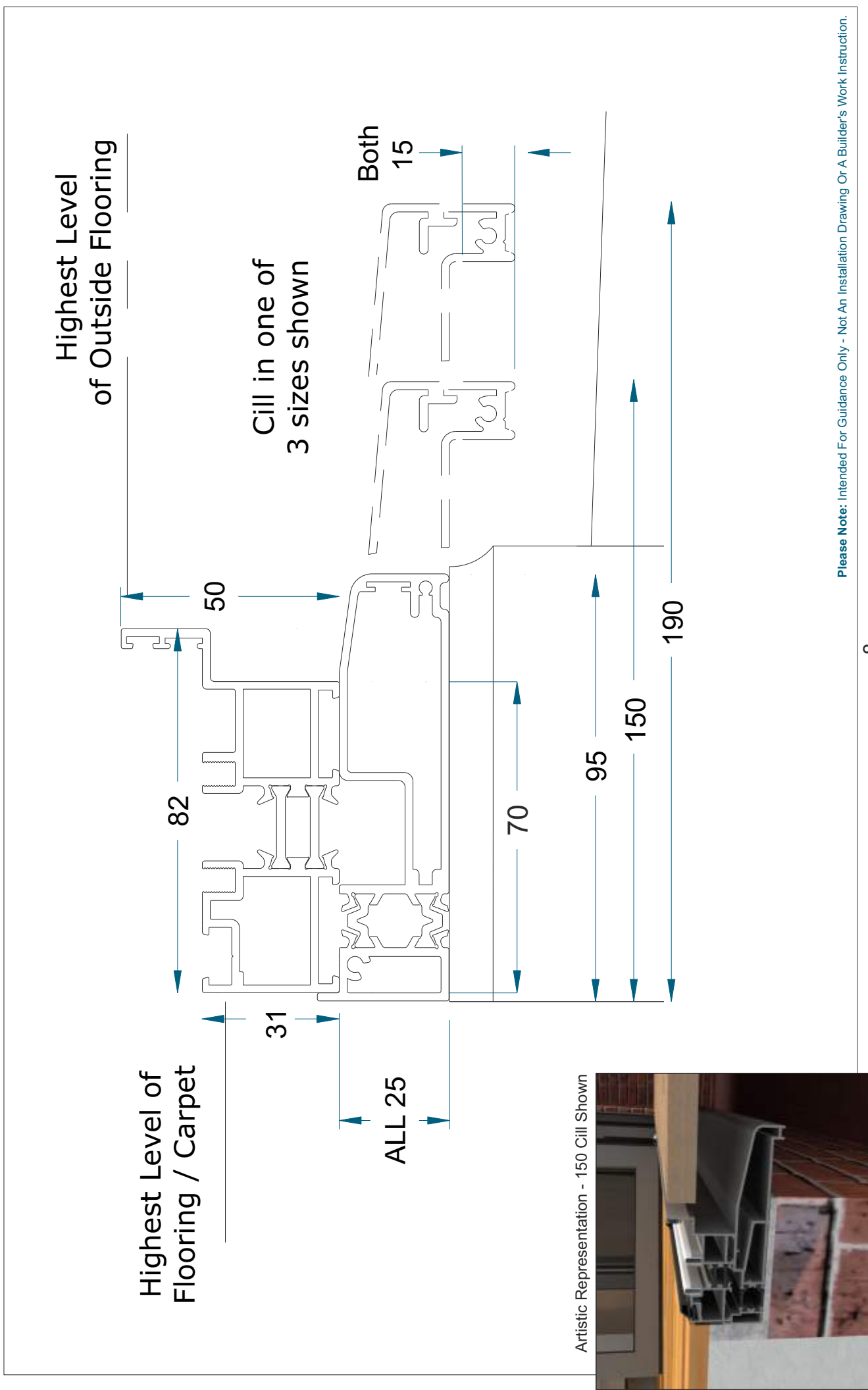



20mm Low Threshold - Ramp To Outside- Open Out

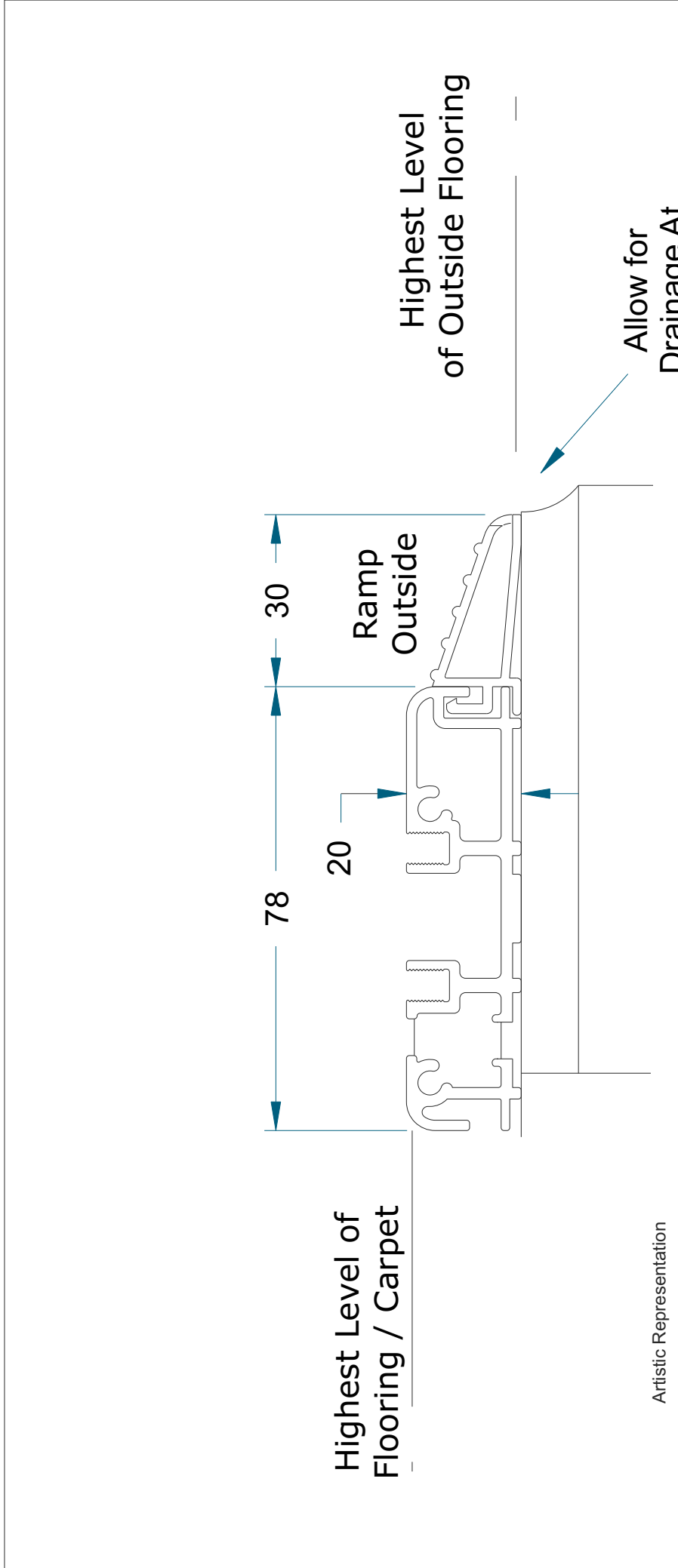

Artistic Representation



20mm Low Threshold - Ramp To Outside - Open In

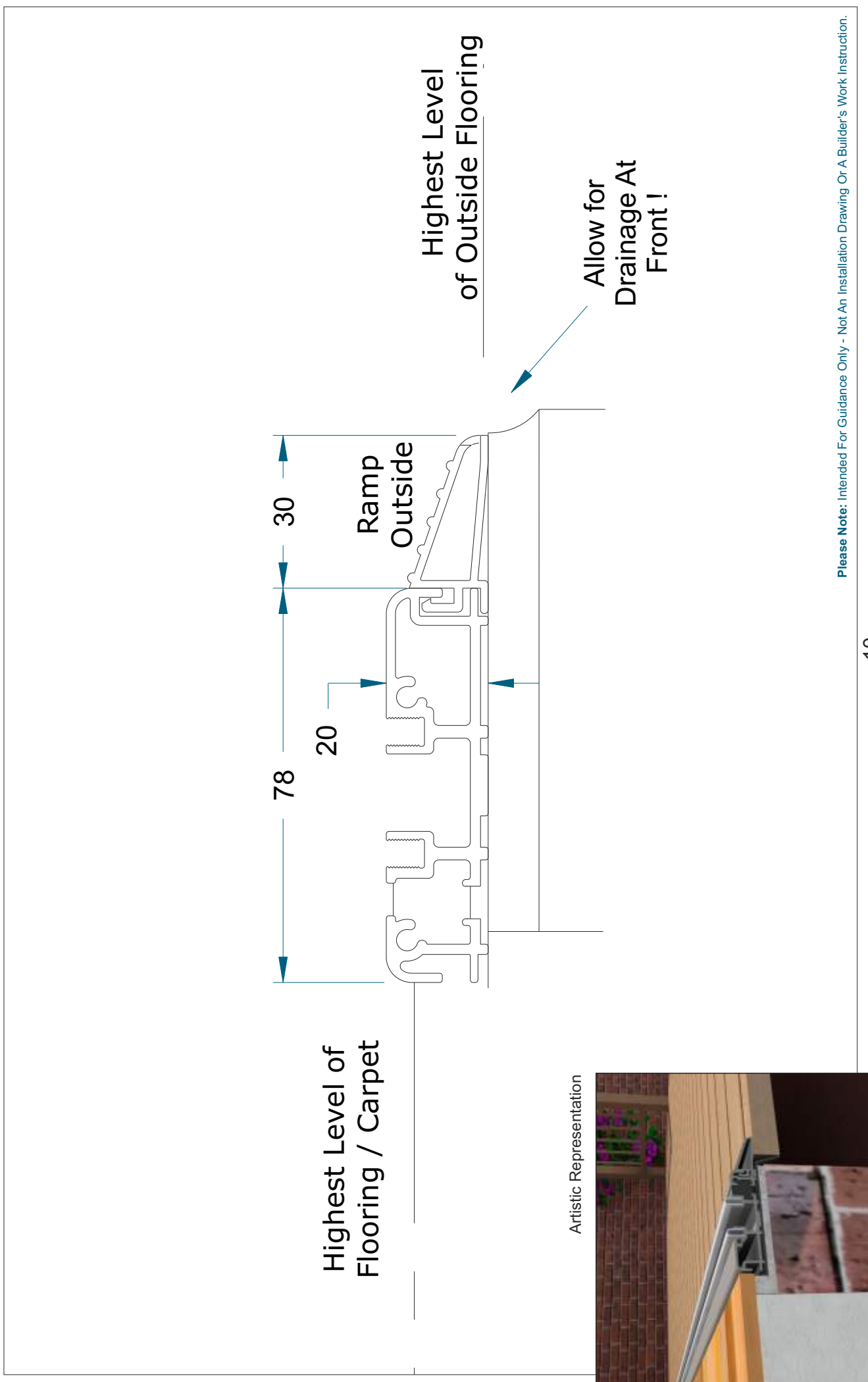

**20mm Low Threshold - Ramp To Inside - Open Out**

Highest Level of  
Flooring / Carpet

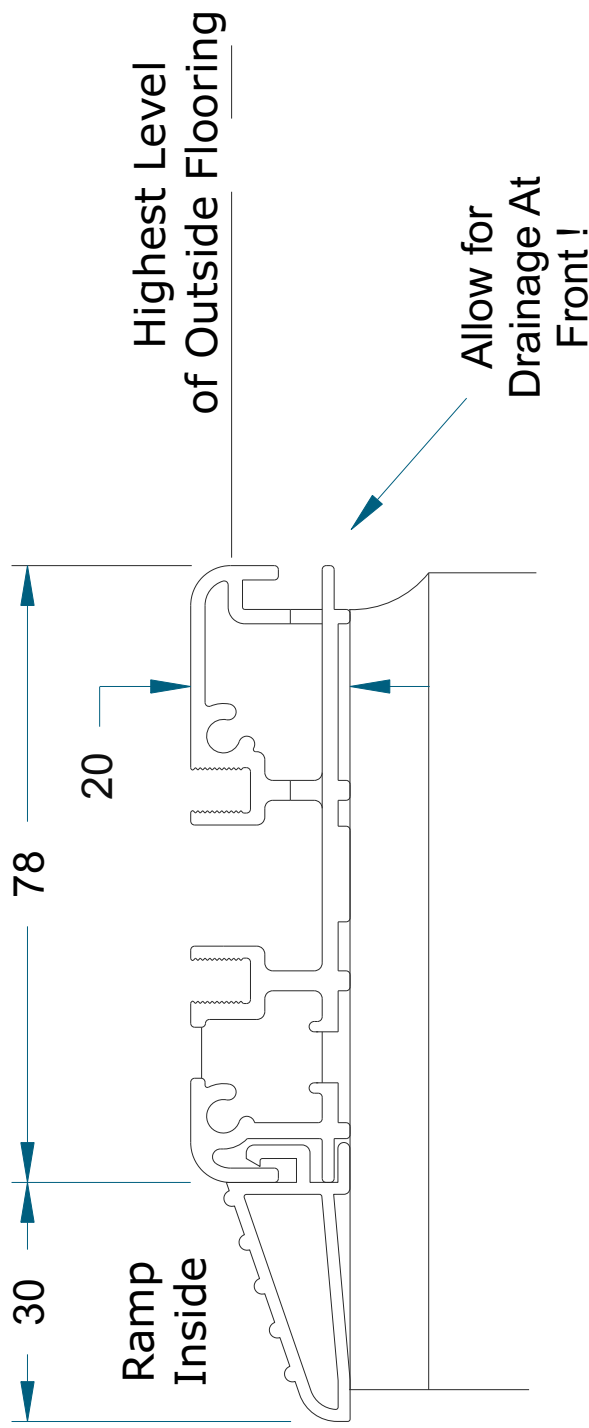

Artistic Representation



**20mm Low Threshold - Ramp To Inside - Open In**

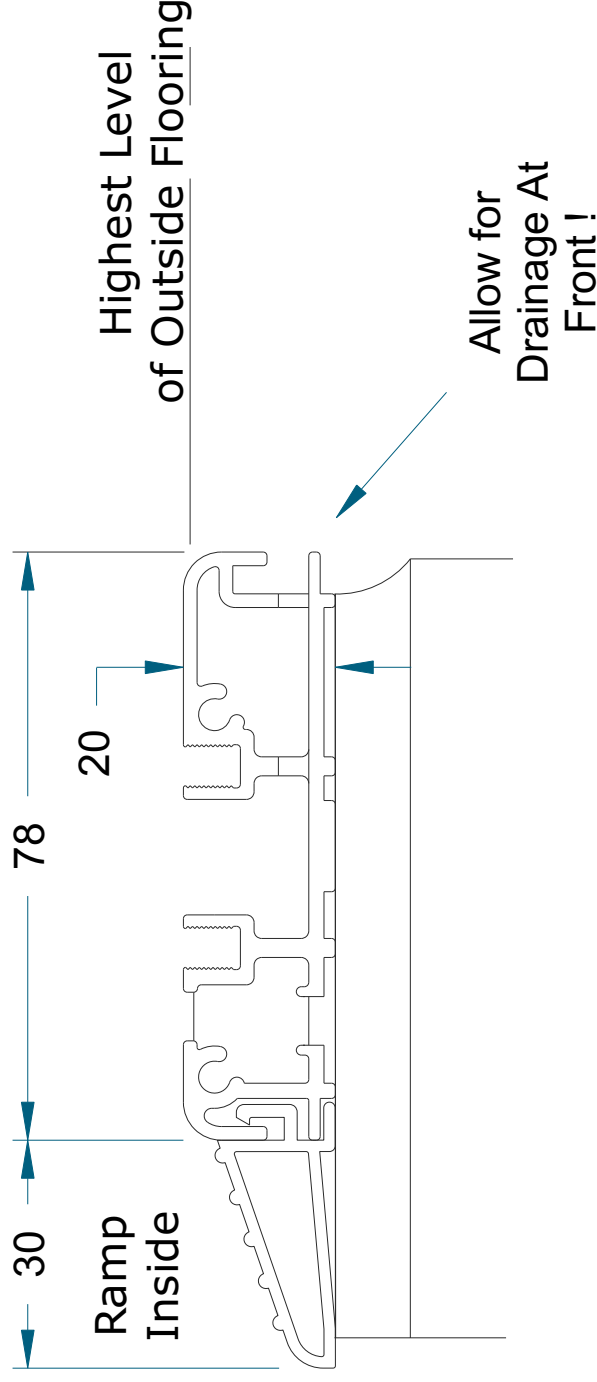

Highest Level of Flooring / Carpet

Artistic Representation



20mm Low Threshold - No Ramps - Open Out

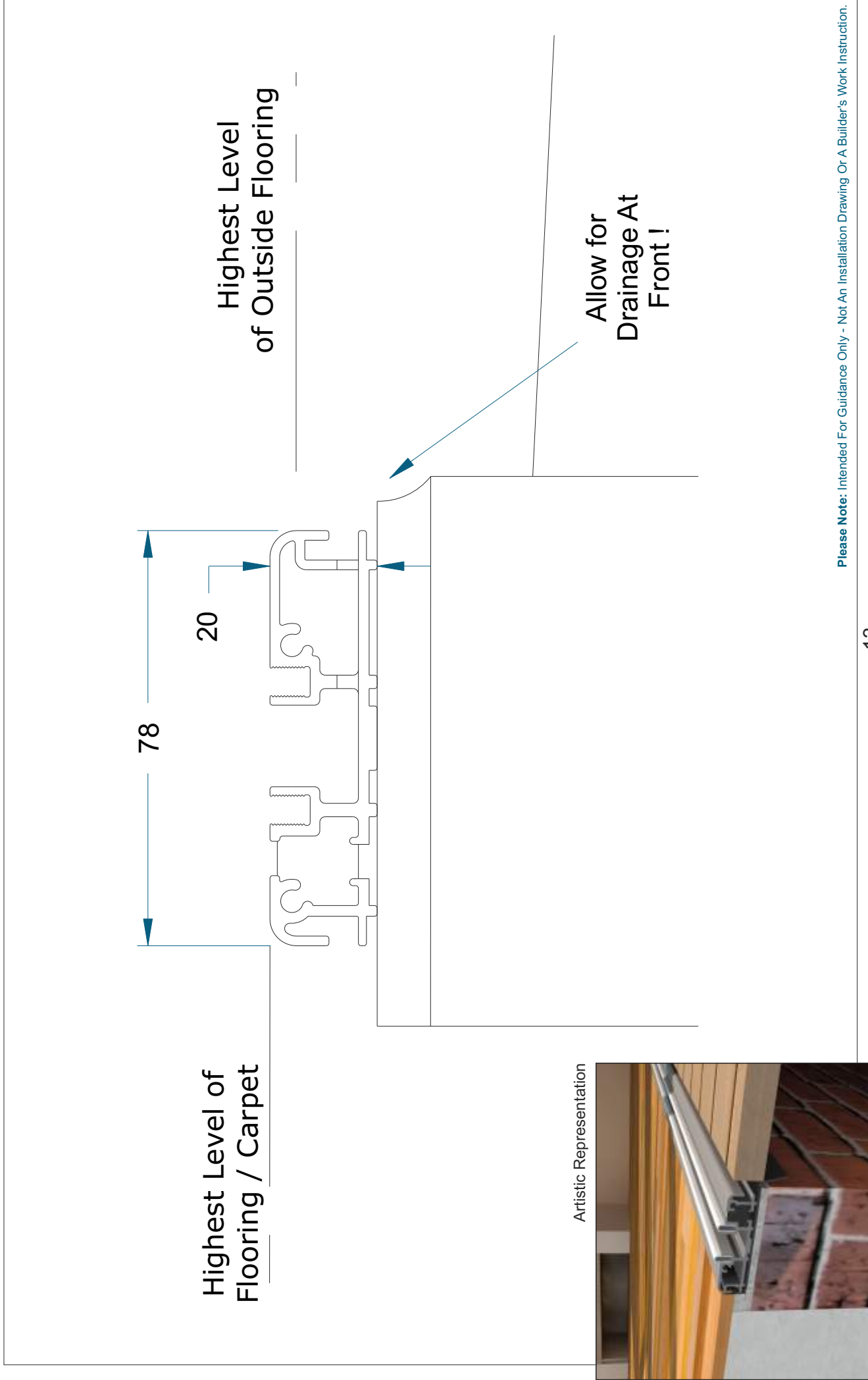

20mm Low Threshold - No Ramps - Open In

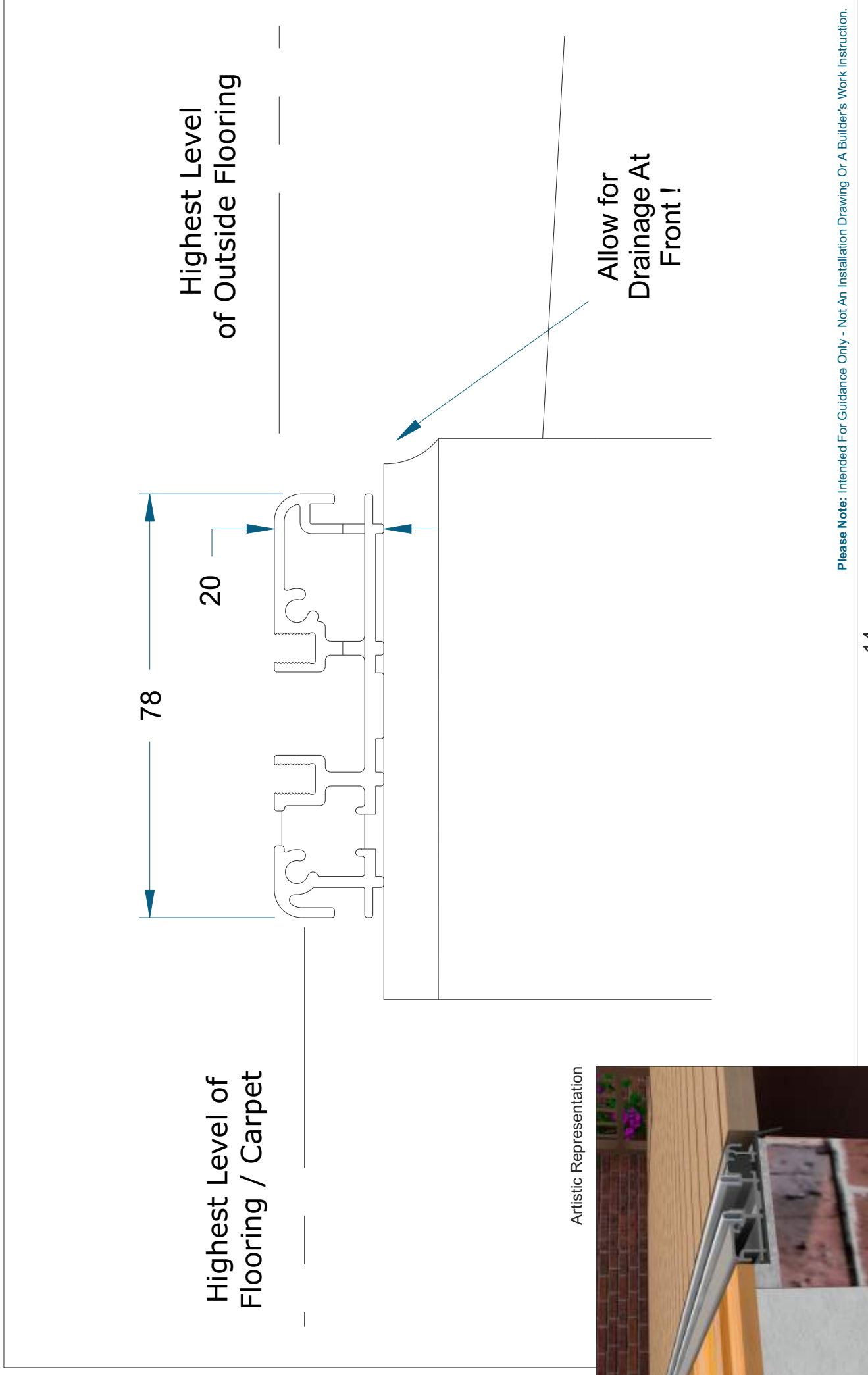

Please Note: Intended For Guidance Only - Not An Installation Drawing Or A Builder's Work Instruction.

**20mm Low Threshold - With Cill - Open Out**

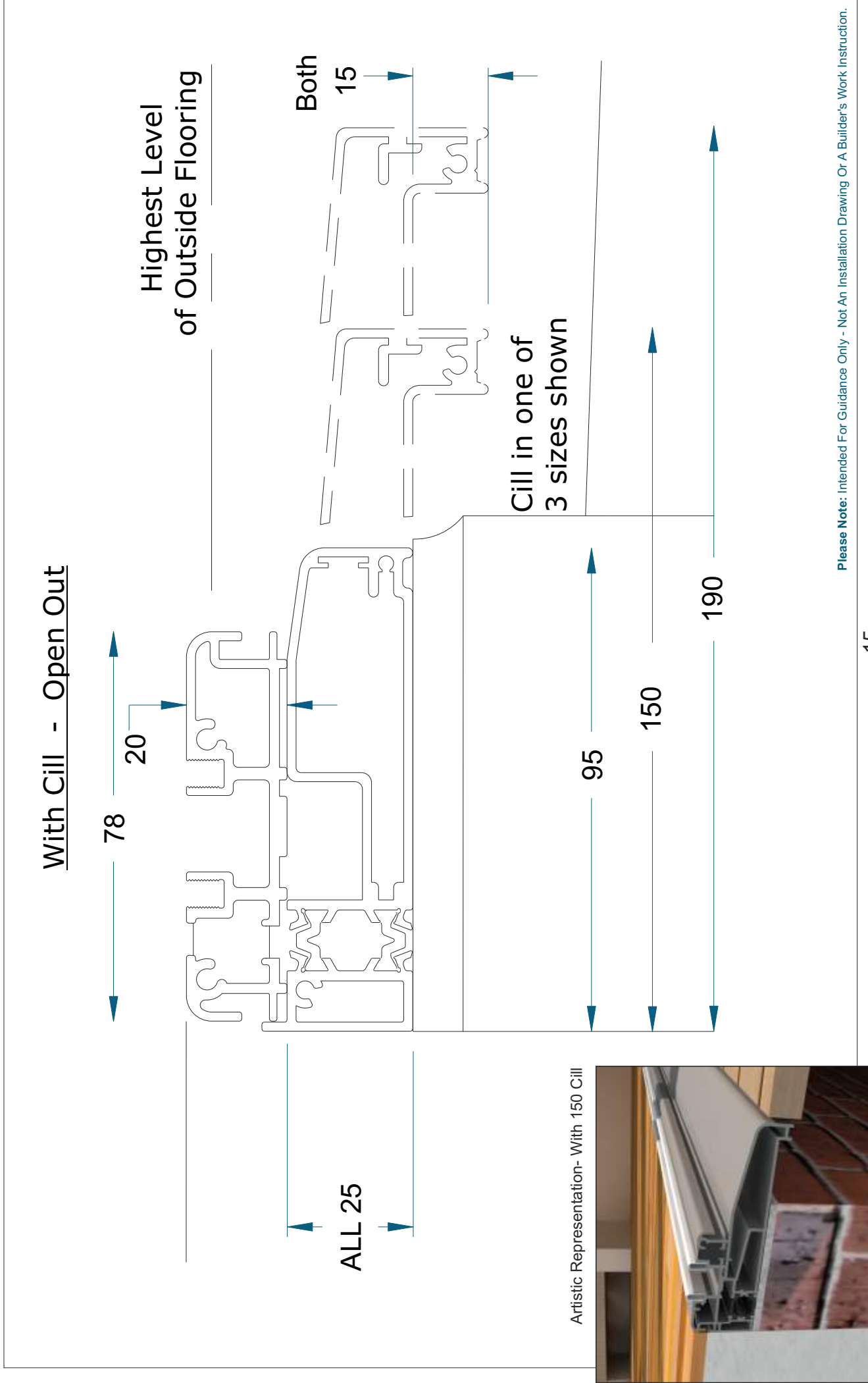

Please Note: Intended For Guidance Only - Not An Installation Drawing Or A Builder's Work Instruction.

**20mm Low Threshold - With Cill - Open In**

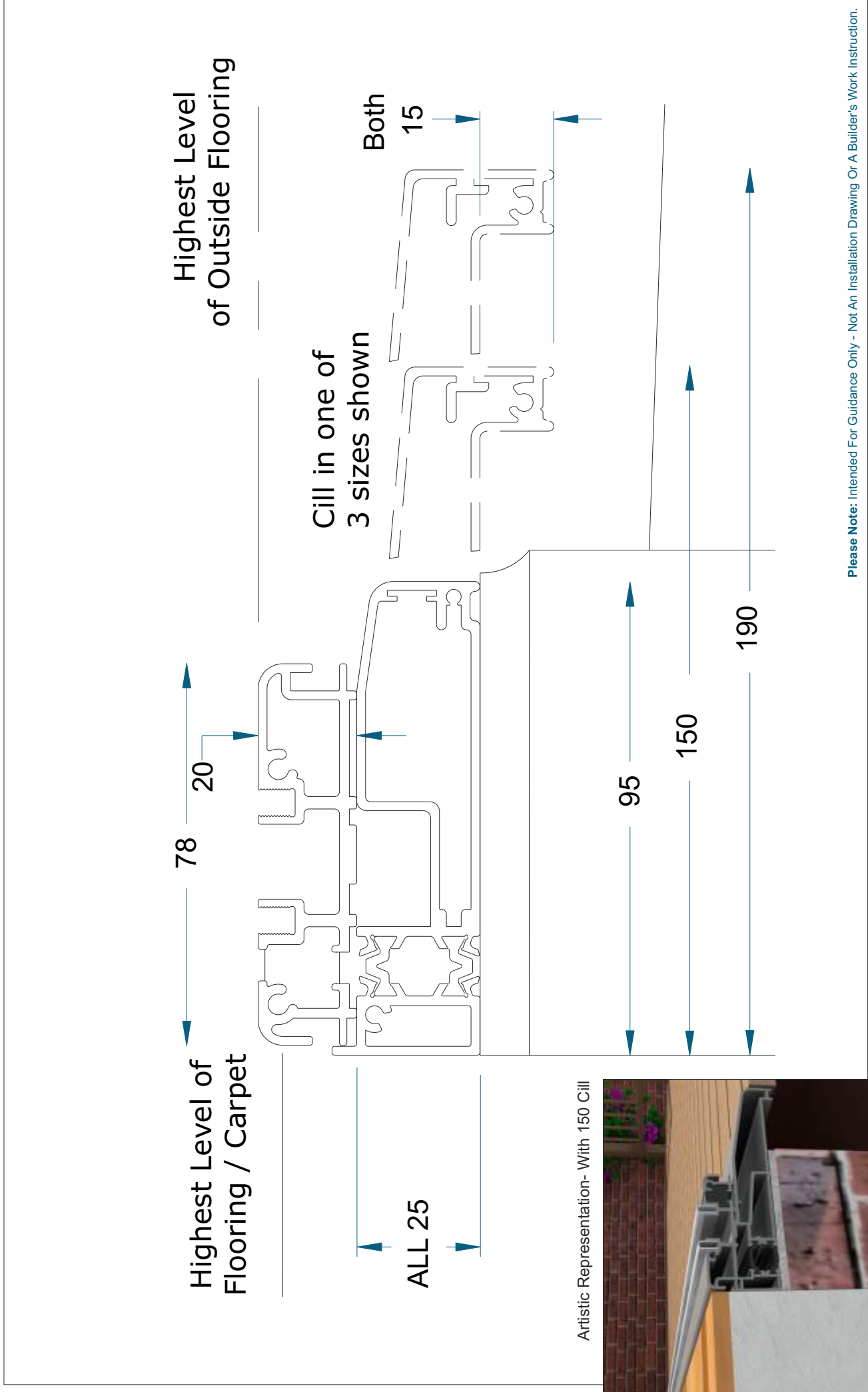

Please Note: Intended For Guidance Only - Not An Installation Drawing Or A Builder's Work Instruction.



15mm Low Threshold - Ramp To Outside - Open Out

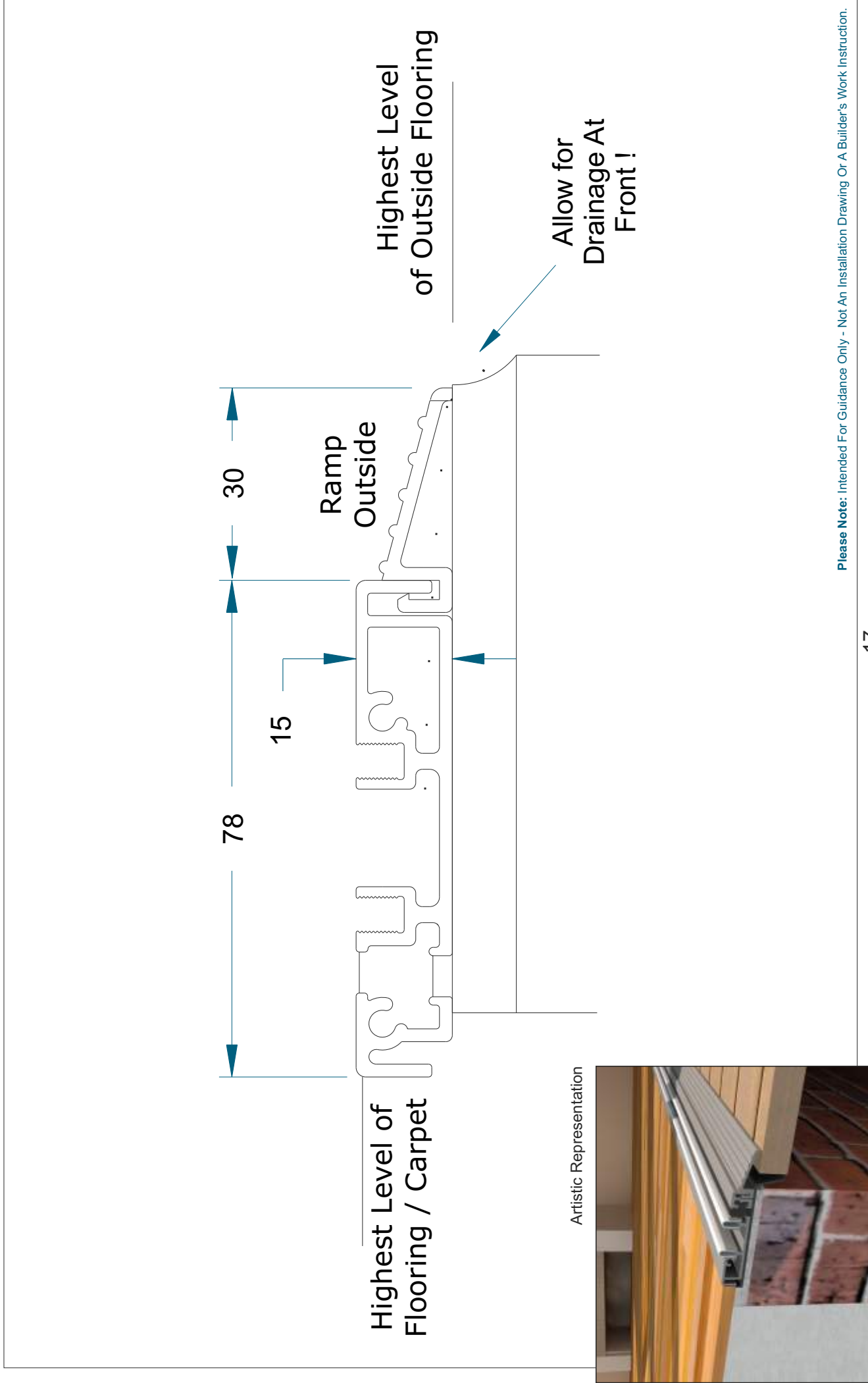

15mm Low Threshold - Ramp To Outside - Open In

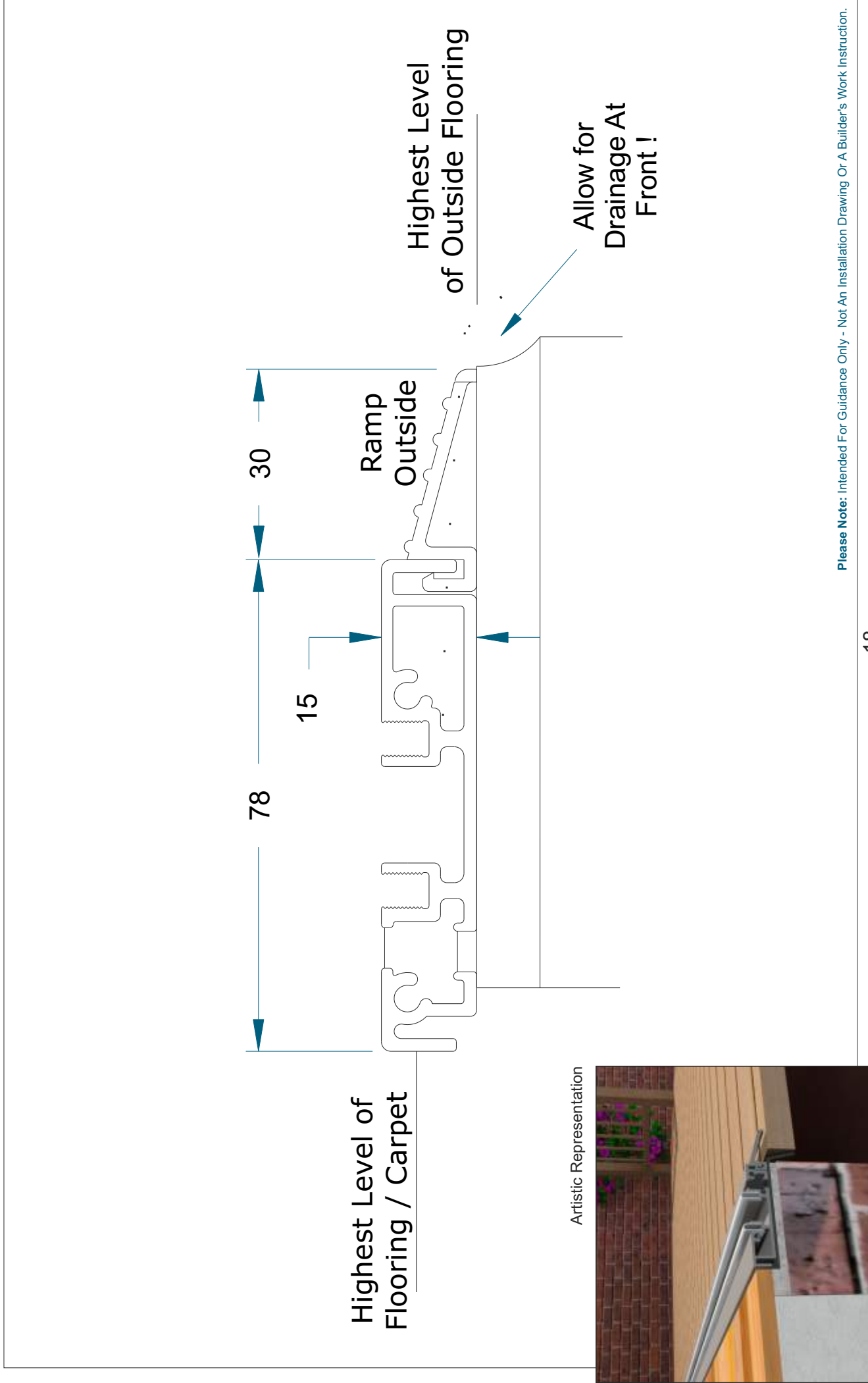

Please Note: Intended For Guidance Only - Not An Installation Drawing Or A Builder's Work Instruction.

**15mm Low Threshold - Ramp To Inside - Open Out**

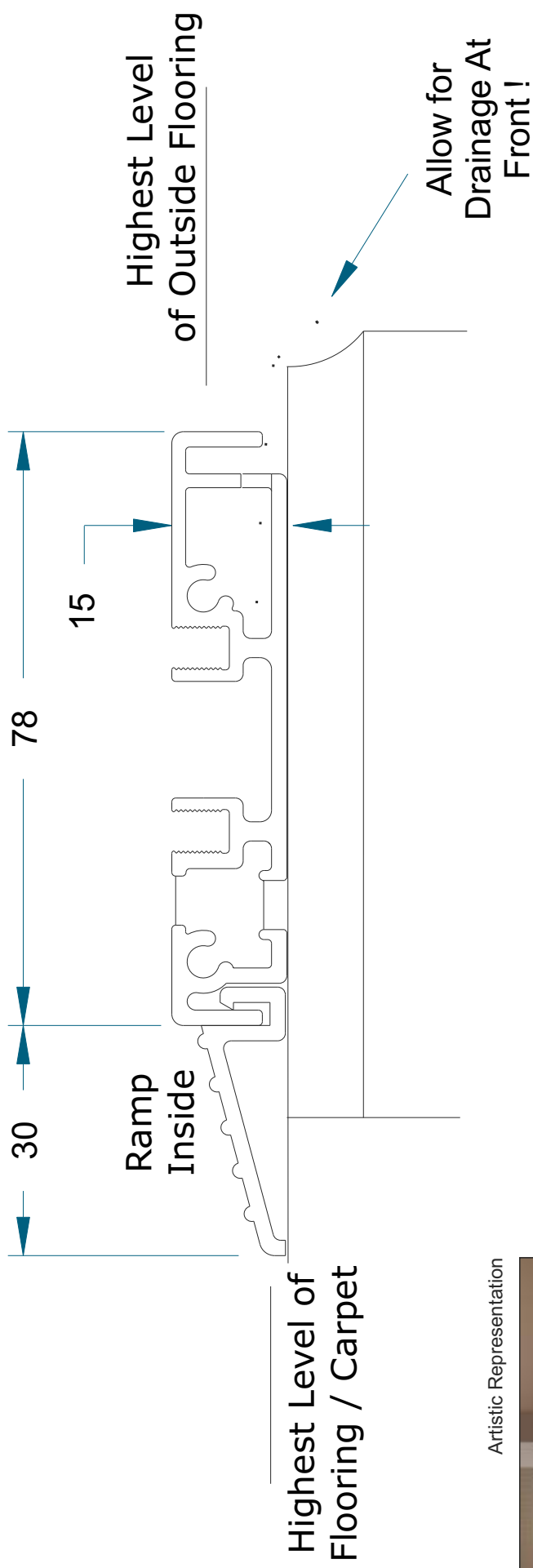

Artistic Representation



**15mm Low Threshold - Ramp To Inside - Open In**

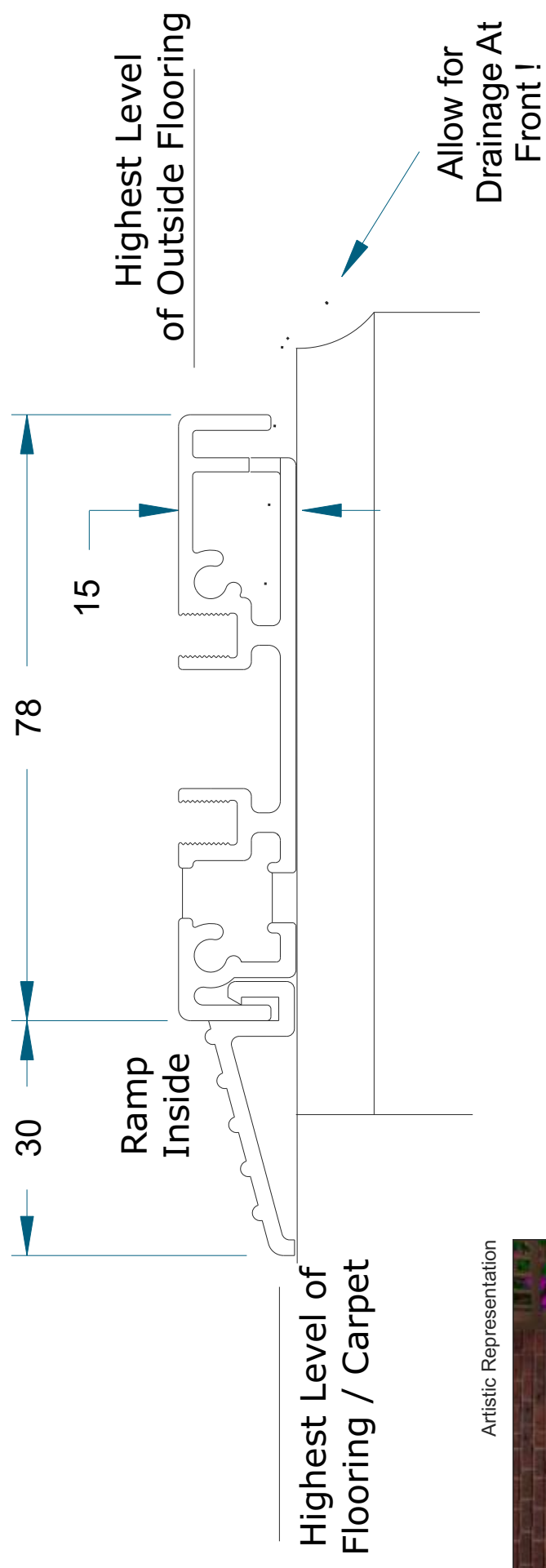

Artistic Representation



15mm Low Threshold - No Ramps - Open Out

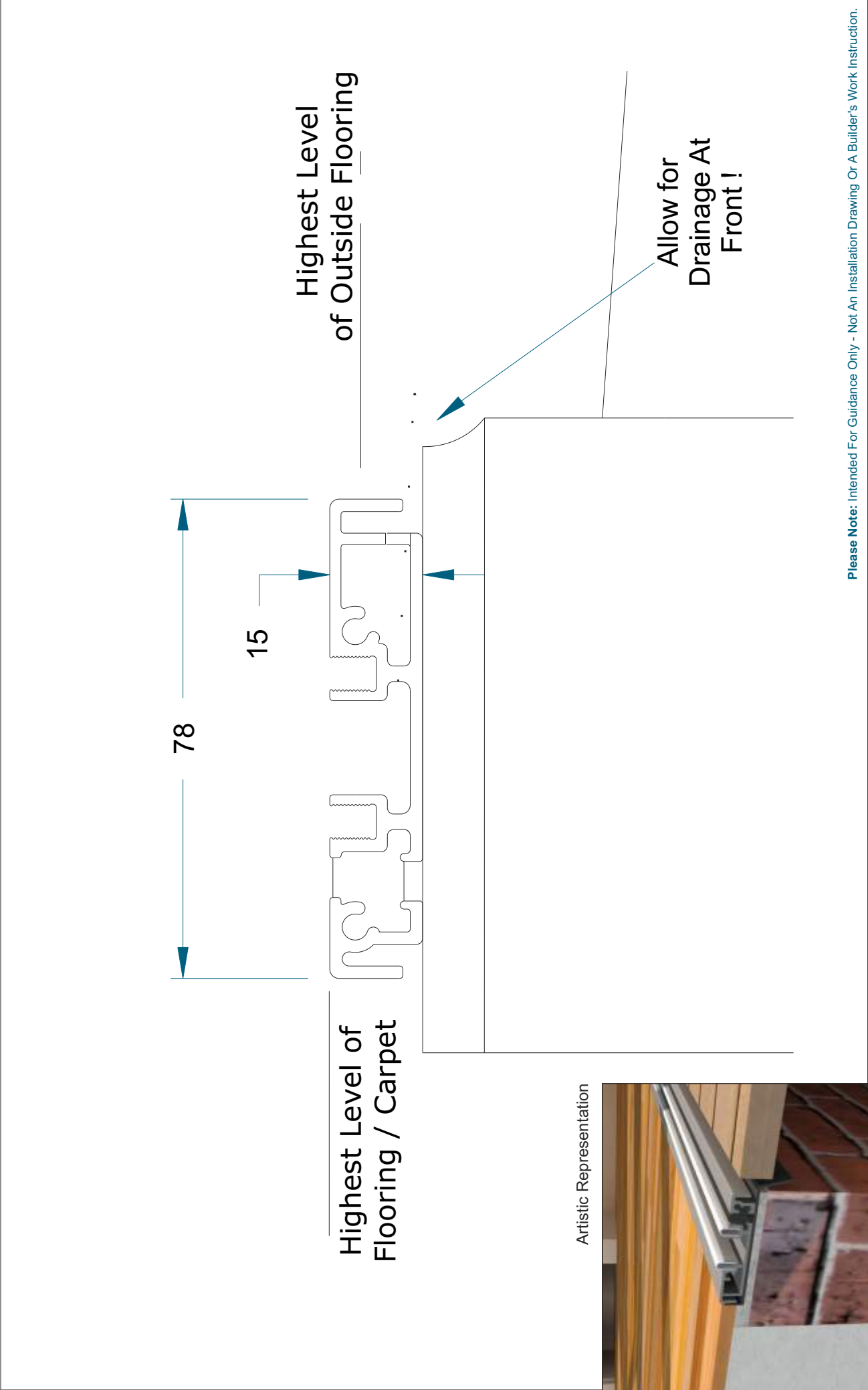

**15mm Low Threshold - No Ramps - Open In**

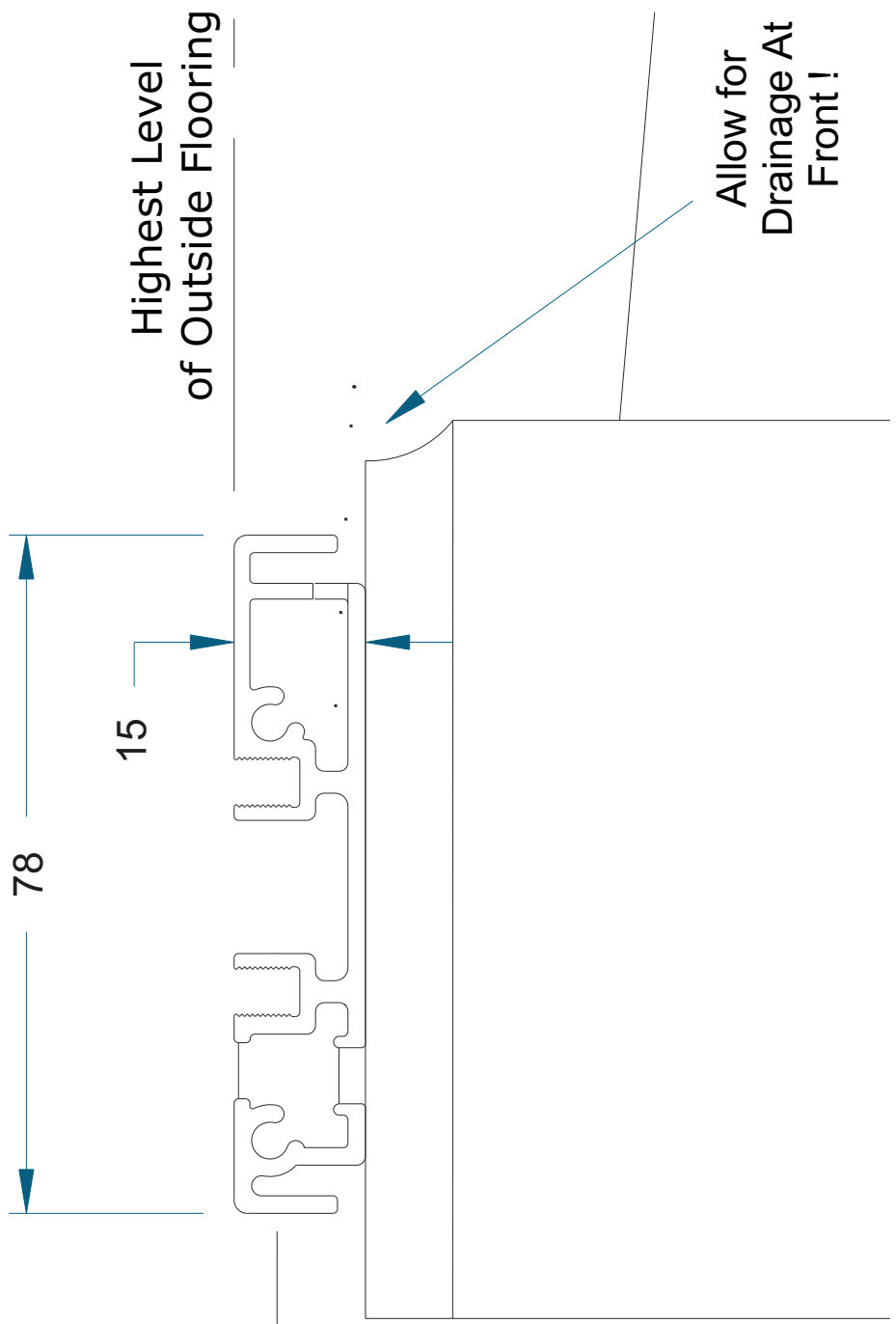

Highest Level of Flooring / Carpet

15

78

Highest Level of Outside Flooring

Allow for Drainage At Front !

Artistic Representation



**15mm Low Threshold - With Cill - Open Out**

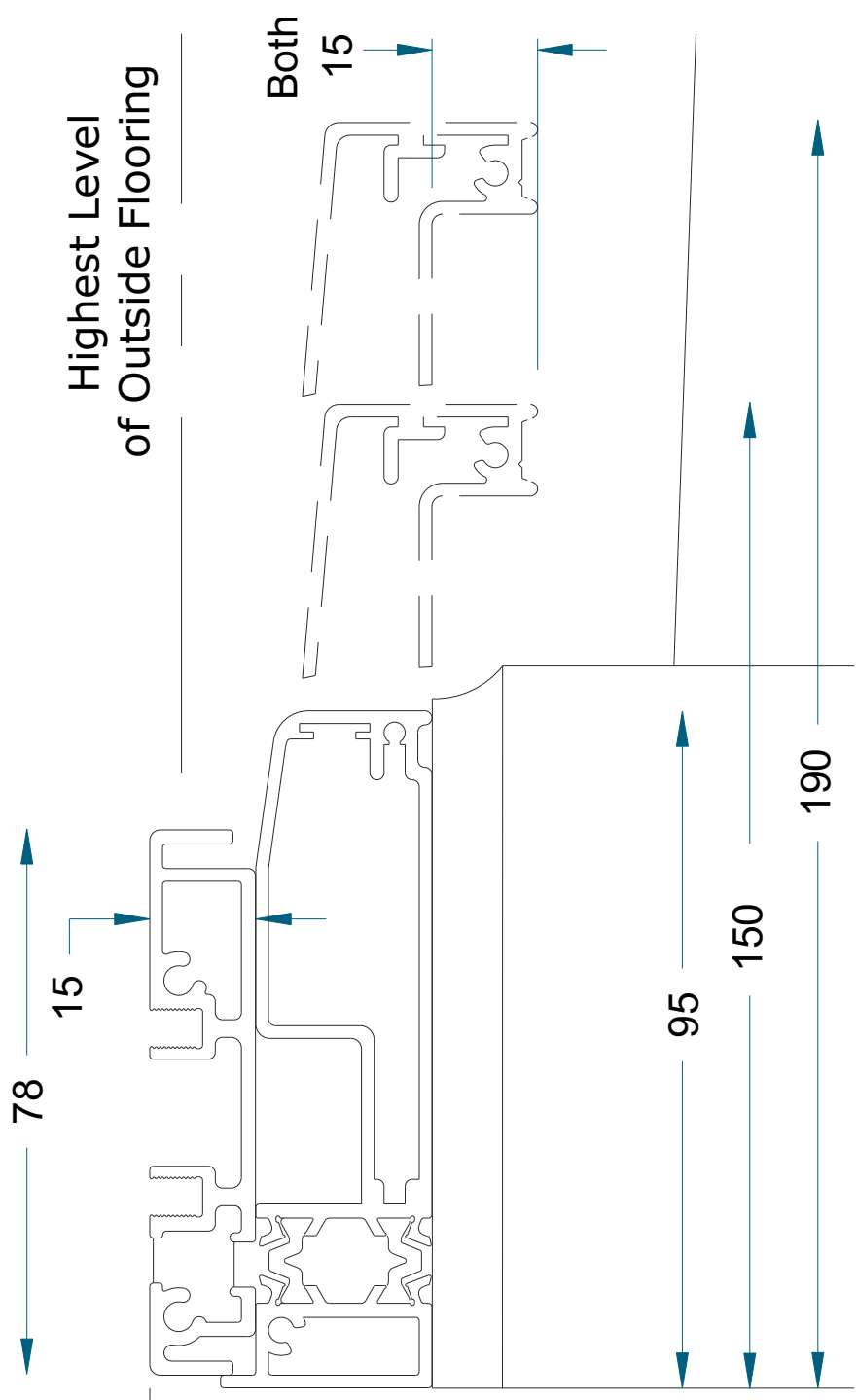

Highest Level of  
Flooring / Carpet

Highest Level  
of Outside Flooring

ALL 25

Both  
15

Artistic Representation- With 150 Cill



Cill in one of  
3 sizes shown

**15mm Low Threshold - With Cill - Open In**

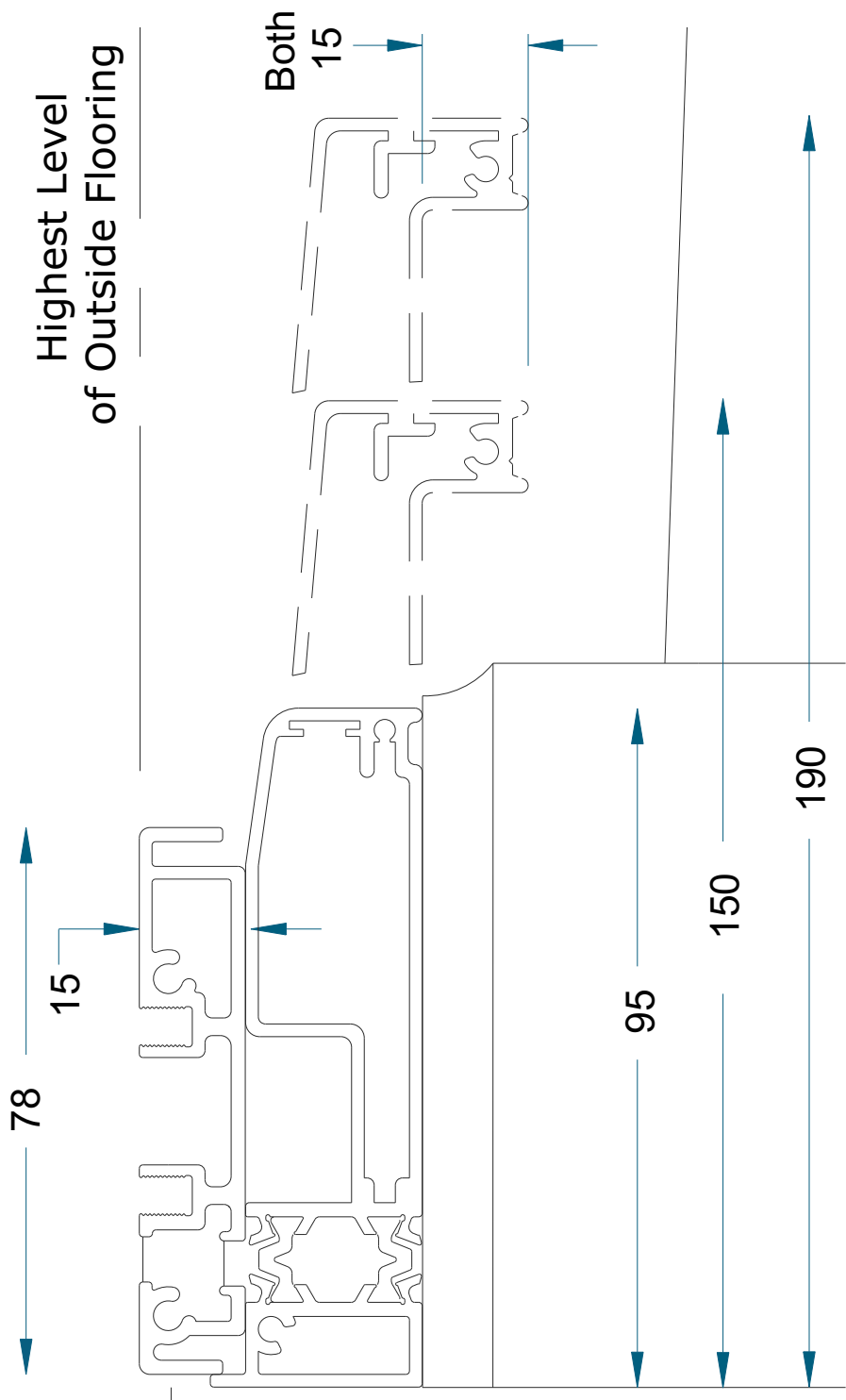

Artistic Representation- With 150 Cill



**Cill in one of  
3 sizes shown**

**Please Note:** Intended For Guidance Only - Not An Installation Drawing Or A Builder's Work Instruction.





**Drainage Paths**

When installing your bifold door and external flooring please take drainage paths into consideration.

Please Note: Drainage caps are not shown.

**Key / Legend**



15mm Low Threshold

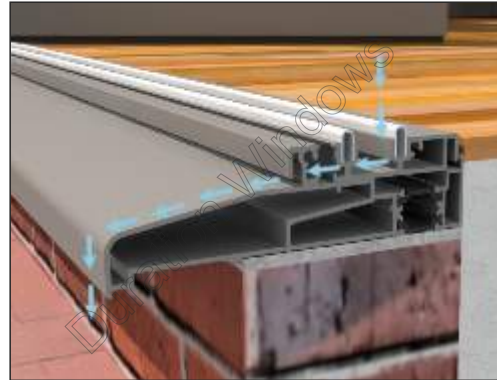

15mm Low Threshold With Cill



20mm Low Threshold

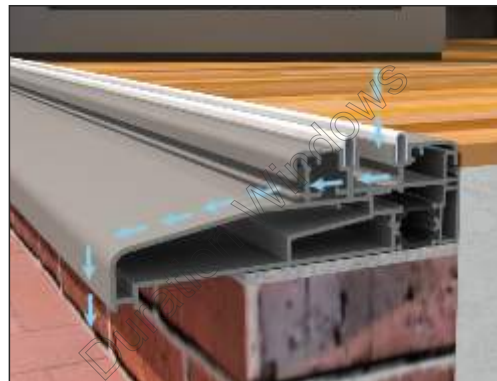

20mm Low Threshold With Cill



Standard Threshold (Open Out)

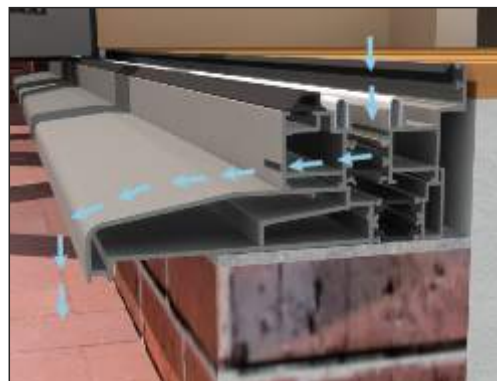

Standard Threshold With Cill (Open Out)

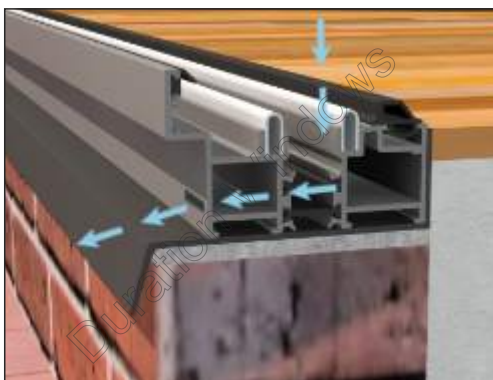

Standard Threshold (Open In)

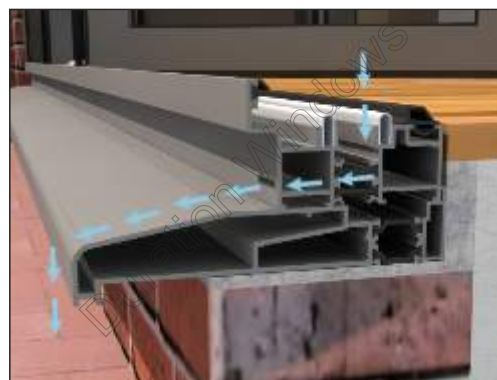

Standard Threshold With Cill (Open In)